



Diee

University of Cagliari
Dept of Electrical and Electronic Eng.

Describing Function analysis *of* **nonlinear systems**

Prof. Elio USAI
eusai@diee.unica.it

University of Leicester
Department of Engineering



System definition and problem statement

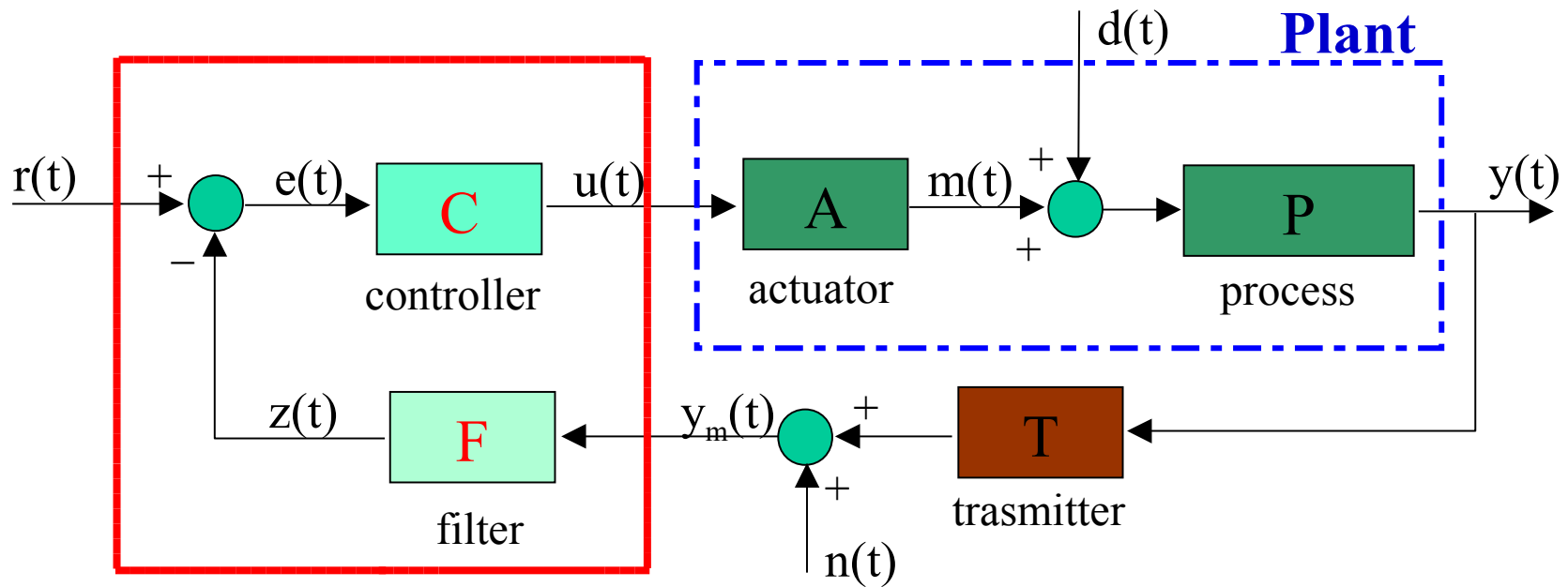

Controller

r : reference variable
 e : error signal
 u : control variable
 m : manipulated input
 y : controlled variable

y_m : measure of the output
 z : feedback signal
 d : disturbance
 n : measurement noise

System definition and problem statement

In many cases the system presents a nonlinear phenomenon which is fully characterised by its static characteristics, i.e., its dynamics can be neglected

- Saturated actuators
- Relay control
- Gears backlash
- Hysteresis in magnetic materials
- Dead zone in electro-mechanical systems

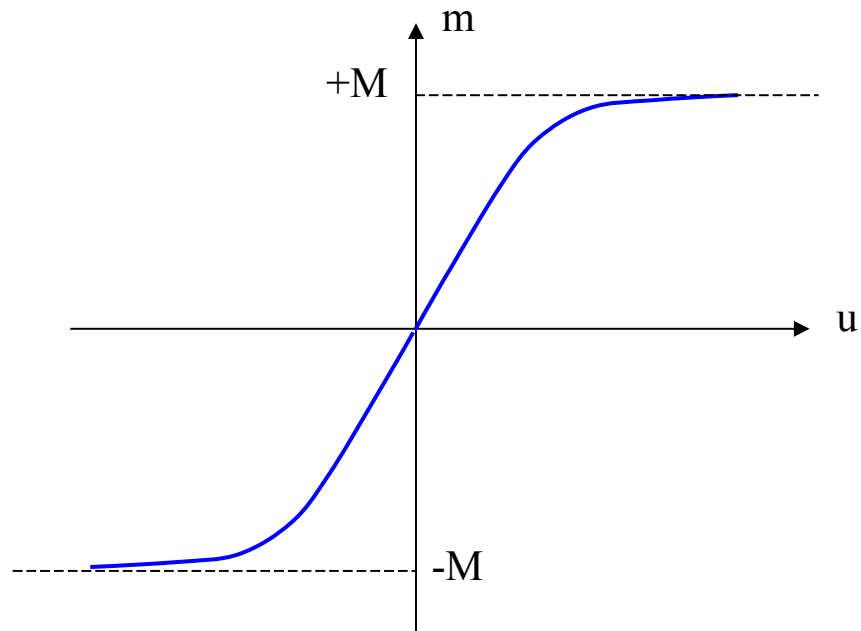

System definition and problem statement

In many cases the system presents a nonlinear phenomenon which is fully characterised by its static characteristics, i.e., its dynamics can be neglected

- Saturated actuators
- **Relay control**
- Gears backlash
- Hysteresis in magnetic materials
- Dead zone in electro-mechanical systems

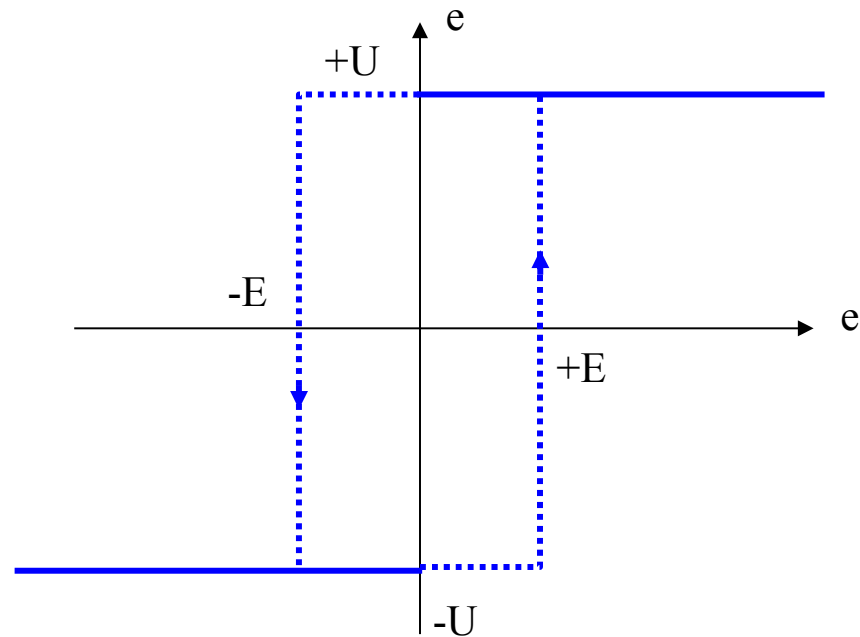

System definition and problem statement

In many cases the system presents a nonlinear phenomenon which is fully characterised by its static characteristics, i.e., its dynamics can be neglected

- Saturated actuators
- Relay control
- **Gears backlash**
- Hysteresis in magnetic materials
- Dead zone in electro-mechanical systems

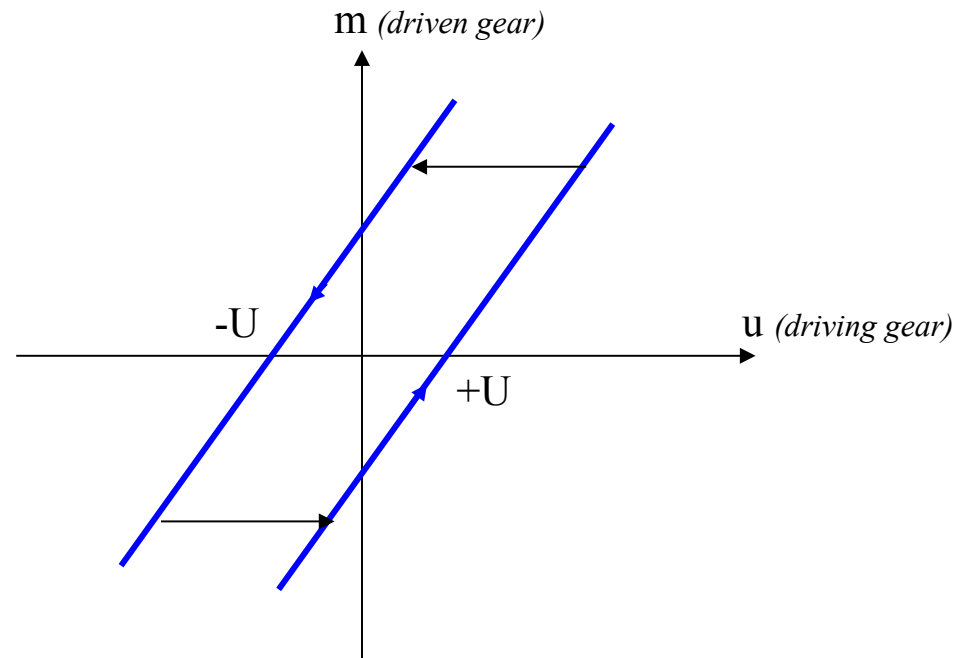

System definition and problem statement

In many cases the system presents a nonlinear phenomenon which is fully characterised by its static characteristics, i.e., its dynamics can be neglected

- Saturated actuators
- Relay control
- Gears backlash
- Hysteresis in magnetic materials
- Dead zone in electro-mechanical systems

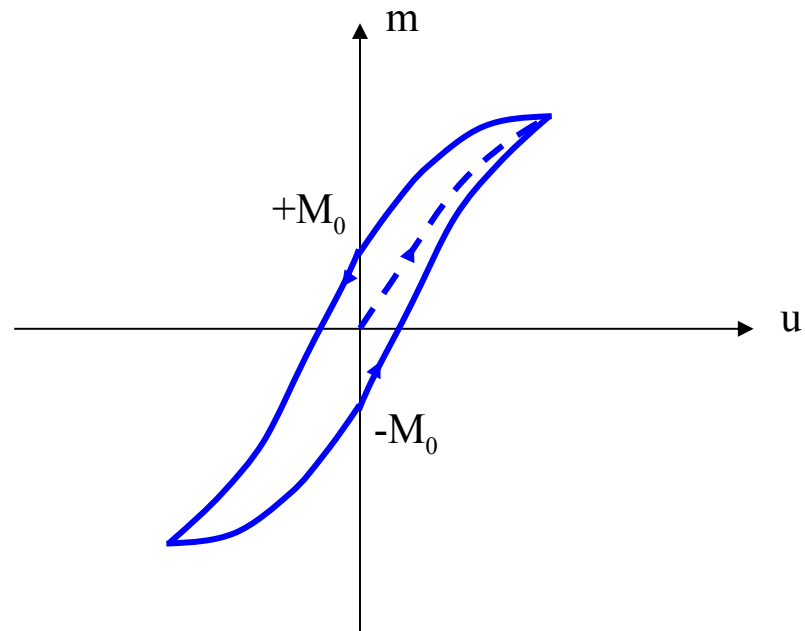

System definition and problem statement

In many cases the system presents a nonlinear phenomenon which is fully characterised by its static characteristics, i.e., its dynamics can be neglected

- Saturated actuators
- Relay control
- Gears backlash
- Hysteresis in magnetic materials
- Dead zone in electro-mechanical systems

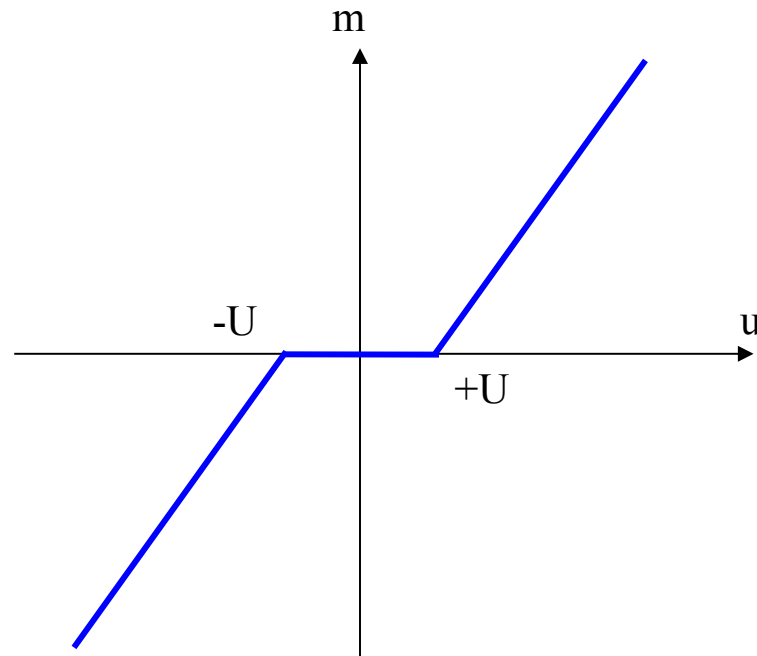

System definition and problem statement

Nonlinearities are not always a drawback, they can also have a “*stabilising*” effect

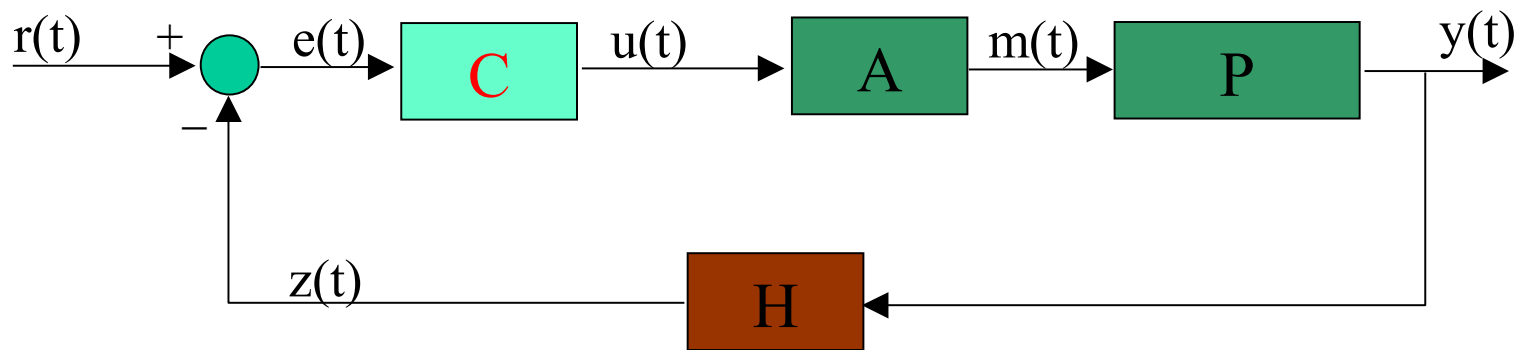

$$P(s) = \frac{1}{s(1 + 1.4s + s^2)}$$

$$H(s) = \frac{0.5}{(1 + 0.1s)}$$

$$C(s) = 10$$

$$A(s) = \begin{matrix} \cdot \cdot \cdot & 1 \\ \cdot \cdot & \\ \cdot & \\ & \cdot \cdot \end{matrix} \text{sat}(\pm 2)$$

System definition and problem statement

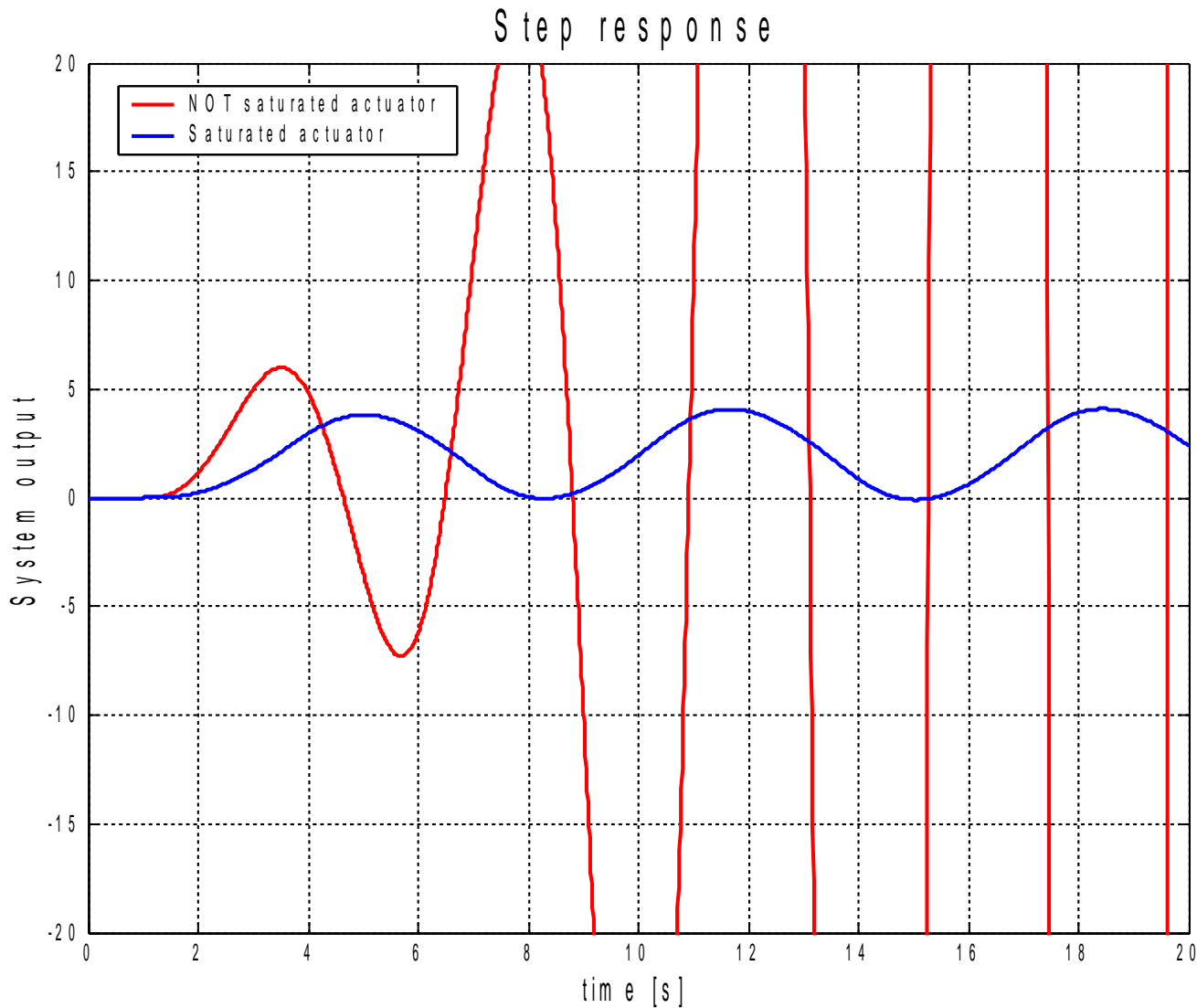

The saturated system oscillates but does not diverge

System definition and problem statement

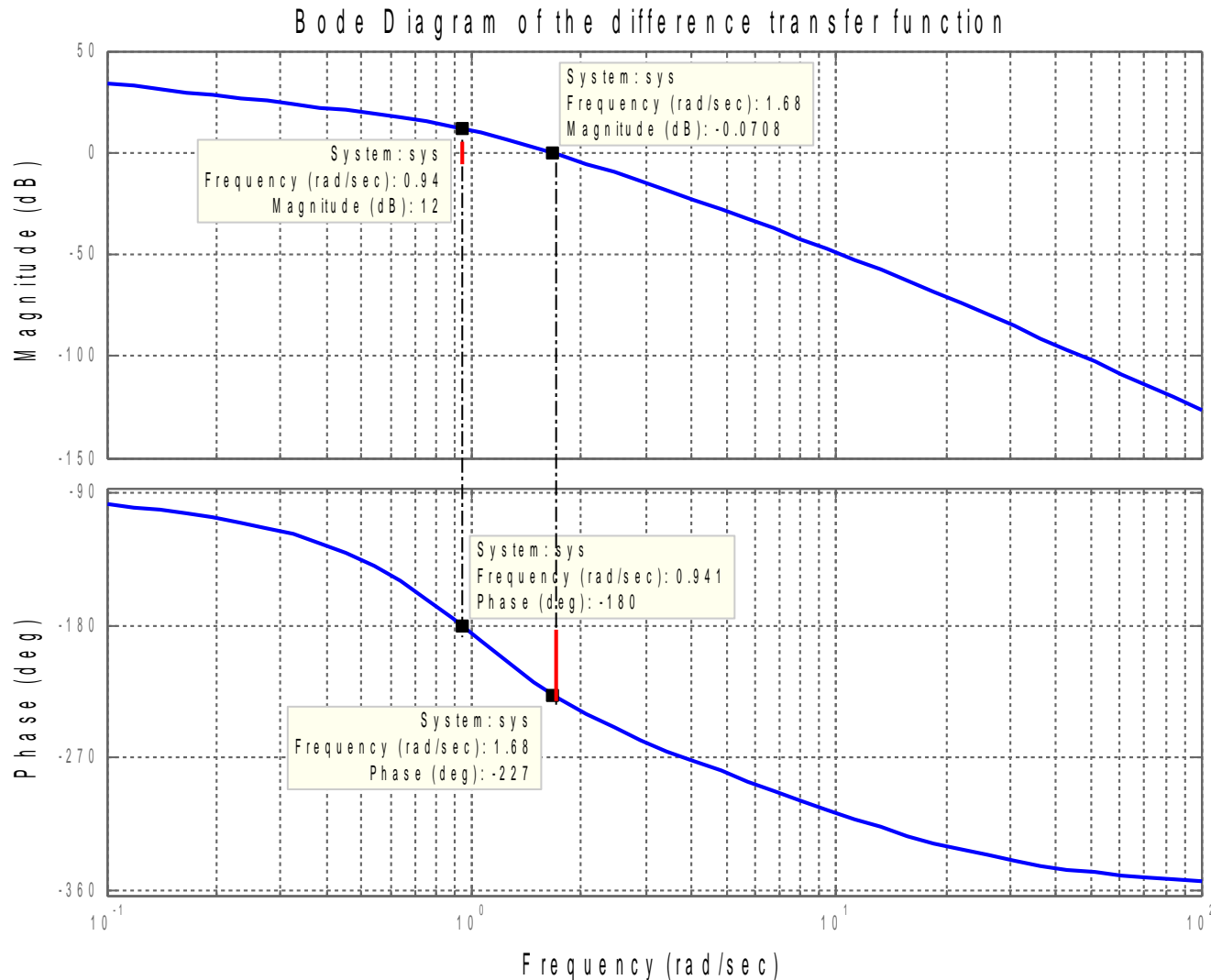

The NOT saturated system is not stable since its stability margin are negatives

- $m_g = -12 \text{ dB}$
- $m_\phi = -47 \text{ deg}$

System definition and problem statement

Many systems can be reduced to a simplified form in which all the linear dynamics is concentrated in a unique block and the static non linear characteristics is represented by a separate block

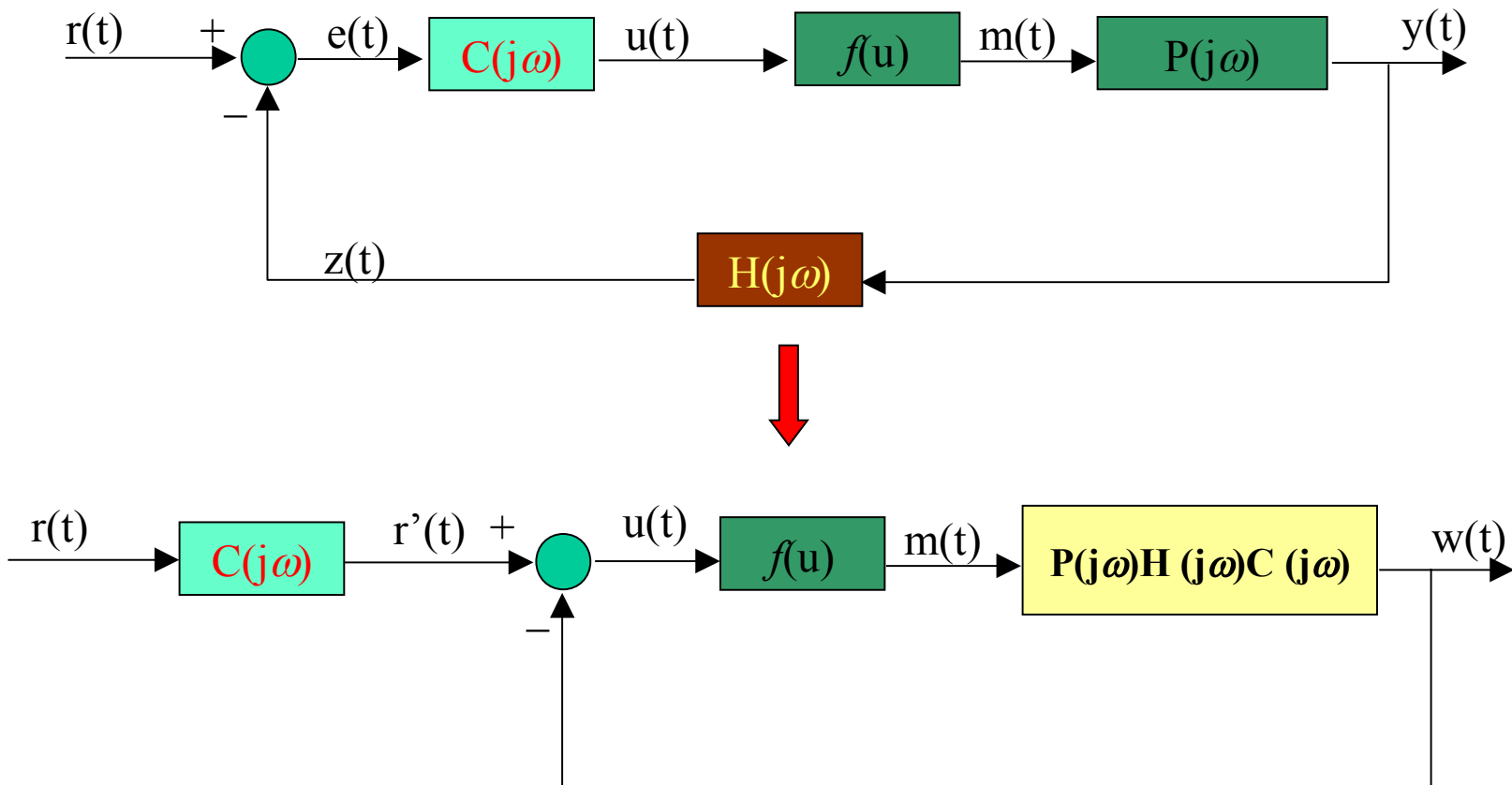

System definition and problem statement

If constant (or very slowly varying) reference signals are considered, under some conditions it is possible to separate the low-frequency, almost static, behaviour defined by a working nominal condition and a high-frequency behaviour due to small variations around such a working point

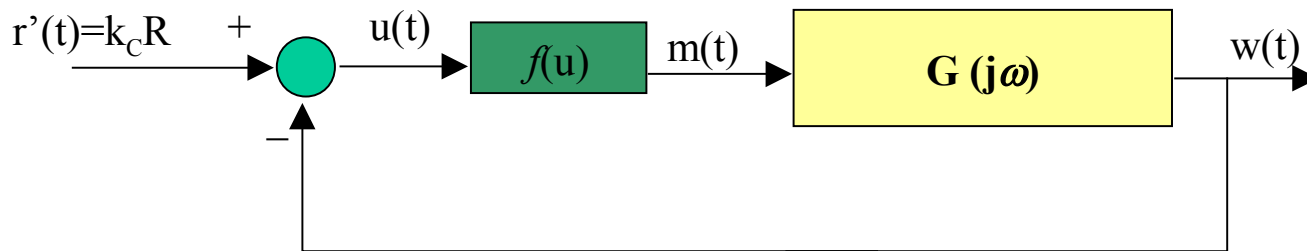
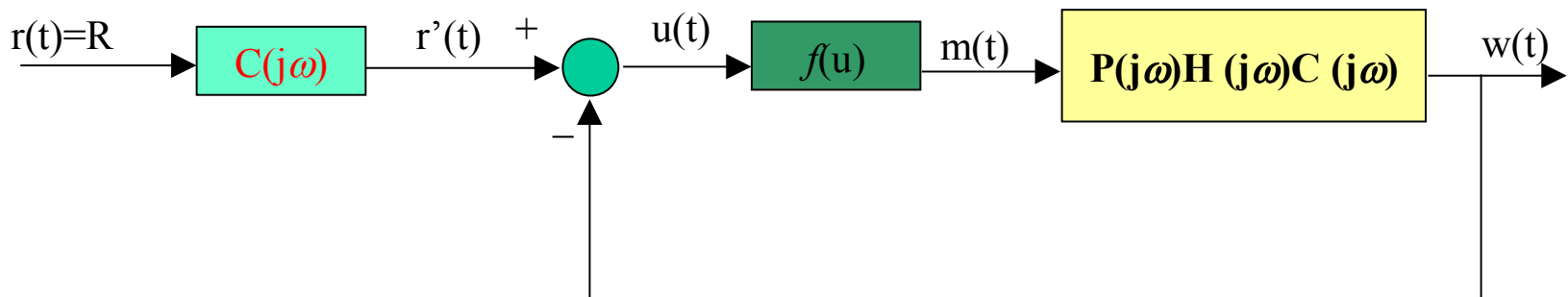

$$u(t) = u_0 + \Delta u(t)$$

$$m(t) = m_0 + \Delta m(t)$$

$$w(t) = w_0 + \Delta w(t)$$

$$u_0 = k_C R - k_G m_0$$

System definition and problem statement

The non linear characteristics is translated so that the origin of the new reference Cartesian system is the point (u_0, m_0) in the original one

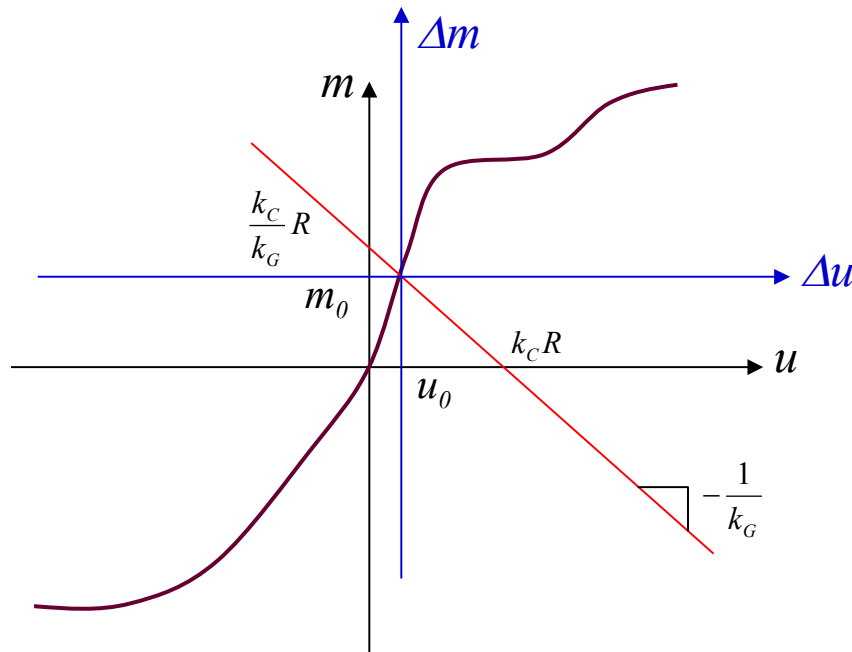

$$\begin{cases} m_0 = f(u_0) \\ u_0 = k_C R - k_G m_0 \end{cases}$$

$$\Delta m_0 = f'(\Delta u)$$

$$f'(\Delta u_0) = f(u_0 + \Delta u) - m_0$$

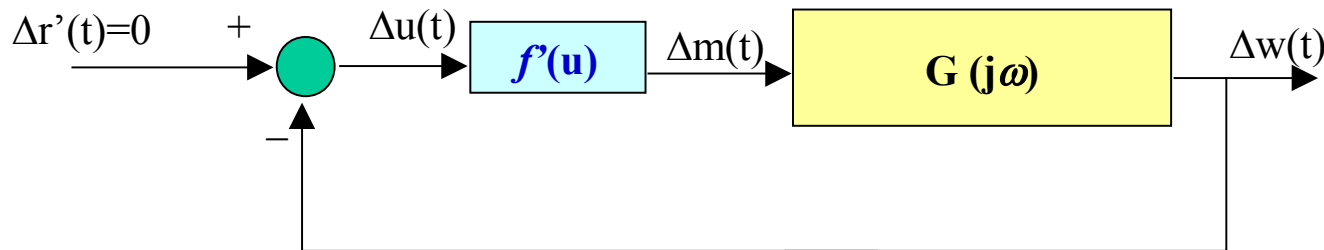

System definition and problem statement

The aim of the system analysis is to define which is the steady-state behaviour of the system defined by the variations around the nominal working point

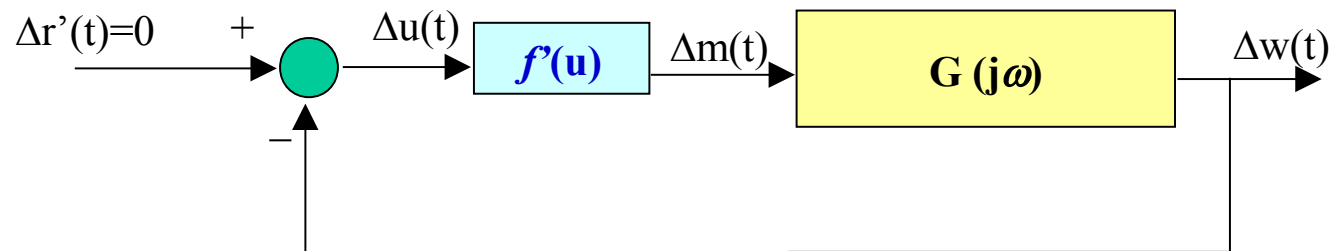

If $f'(u)$ is a passive sector function **absolute stability** tools allow for **sufficient conditions** for global asymptotic stability of the variation system, i.e, the steady state is characterised by constant values of the system variables

If the origin of the variation system is not stable does the variables diverge to infinity or some **periodic motion can appear?**

Limit cycles

Limit cycle: a periodic oscillation around a constant working point

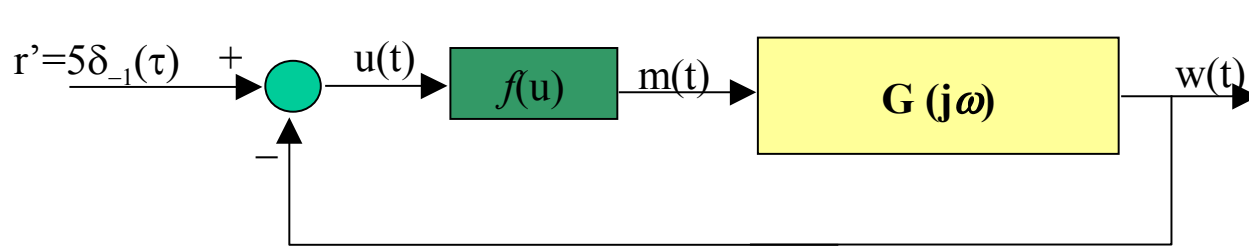

$$G(s) = \frac{10}{(s+1)(s^2 + 1.4s + 1)}$$

$$f(u) = \text{sat}\left(1, -\frac{6}{11}, \frac{16}{11}\right)$$

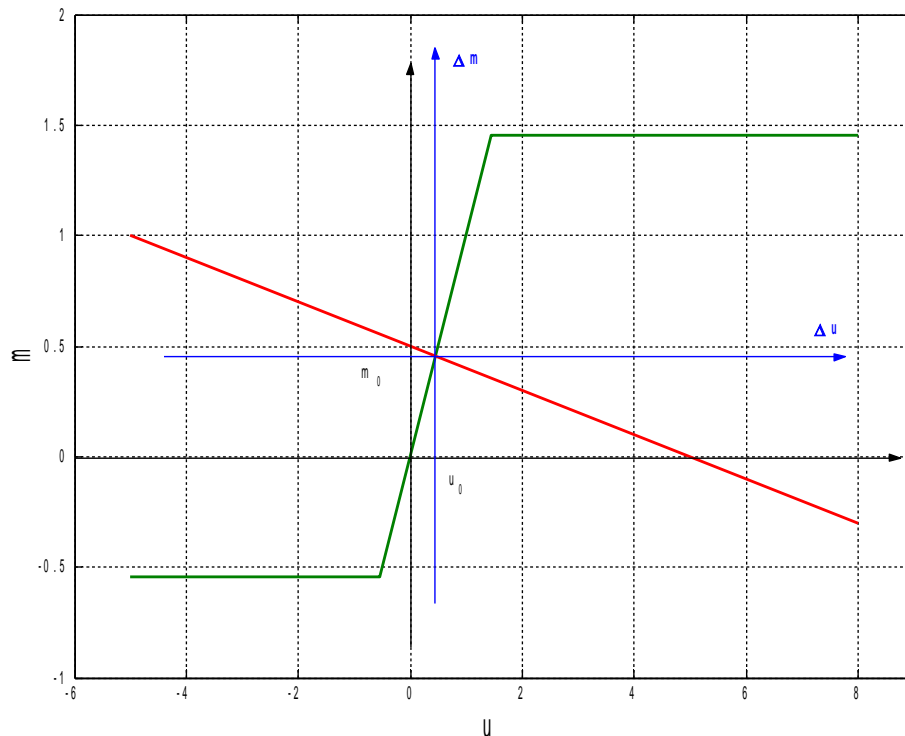

$$m = -\frac{1}{10}u + \frac{1}{2}$$

$$u_0 = \frac{5}{11}$$

$$m_0 = \frac{5}{11}$$

Limit cycles

Limit cycle: a periodic oscillation around a constant working point

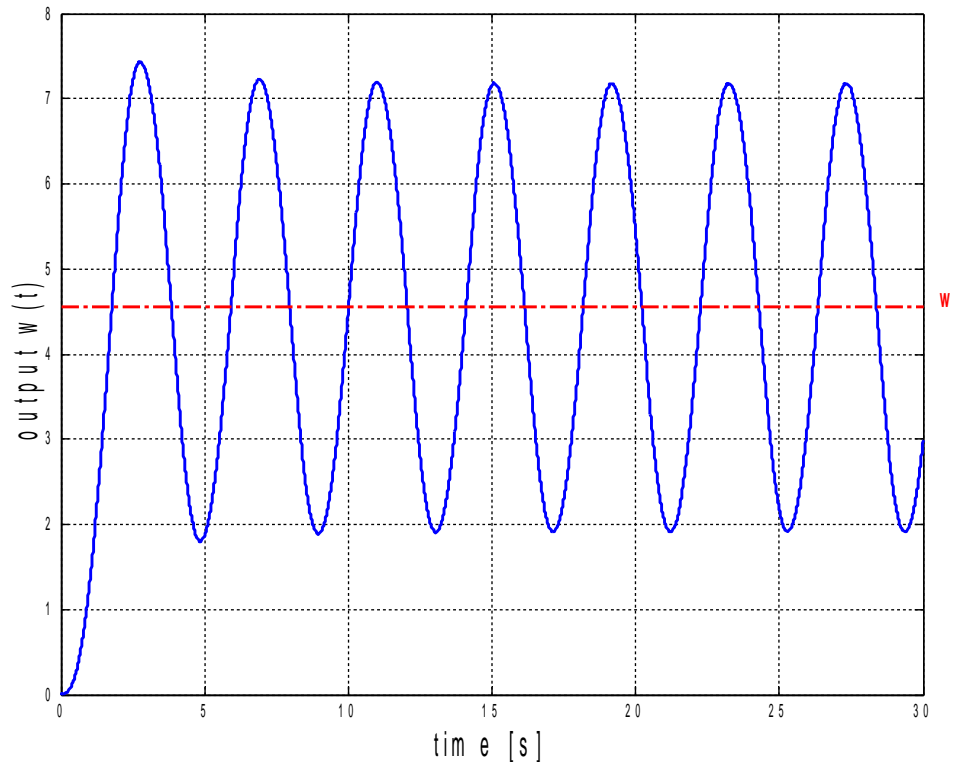
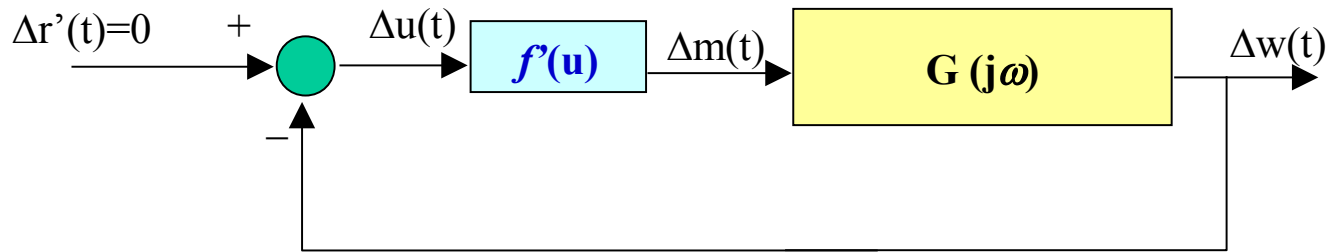

$$u_0 = \frac{5}{11}$$
$$m_0 = \frac{5}{11}$$



$$w_0 = \frac{50}{11} = 4.545$$

Limit cycles

Limit cycle can be a drawback in control systems:

- ✓ *Instability of the equilibrium point*
- ✓ *Wear and failure in mechanical systems*
- ✓ *Loss of accuracy in regulation*

Parameters of the limit cycle can be used to discriminate between acceptable and dangerous oscillations

- oscillation frequency
- oscillation magnitude

Electronic oscillators can be based on limit cycles

Describing Function - *Assumptions*

The describing Function approach to the analysis of steady-state oscillations in non linear systems is an approximate tool to estimate the limit cycle parameters.

It is based on the following assumptions

- ✓ There is only one single nonlinear component
- ✓ The nonlinear component is not dynamical and time invariant
- ✓ The linear component has low-pass filter properties
- ✓ The nonlinear characteristic is symmetric with respect to the origin

Describing Function - *Assumptions*

There is only one single nonlinear component

The system can be represented by a lumped parameters system with two main blocks:

- The linear part
- The nonlinear part

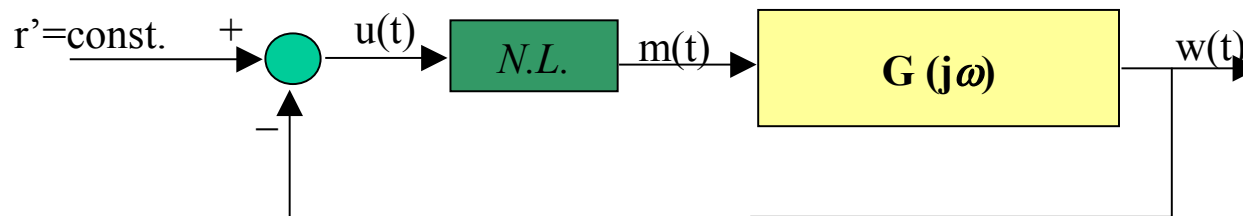

Describing Function - Assumptions

The nonlinear component is not dynamical and time invariant

The system is autonomous.

All the system dynamics is concentrated in the linear part so that classical analysis tools such as Nyquist and Bode plots can be applied.

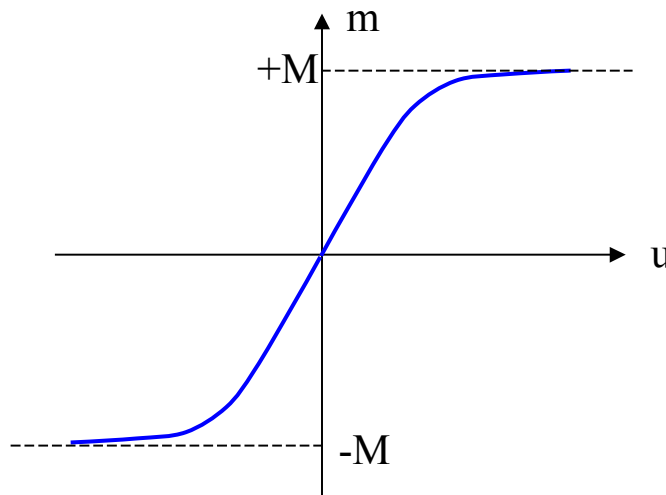

$$m = M \frac{u}{|u| + \varepsilon}$$

Describing Function - *Assumptions*

The linear component has low-pass filter properties

This is the main assumption that allows for neglecting the higher frequency harmonics that can appear when a nonlinear system is driven by a harmonic signal

$$|G(j\bar{\omega})| \gg |G(jn\bar{\omega})| \quad n = 2, 3, \dots$$

The more the low-pass filter assumption is verified the more the estimation error affecting the limit cycle parameters is small

Describing Function - *Assumptions*

The nonlinear characteristic is symmetric with respect to the origin

This guarantees that the static term in the Fourier expansion of the output of the nonlinearity, subjected to an harmonic signal, can be neglected

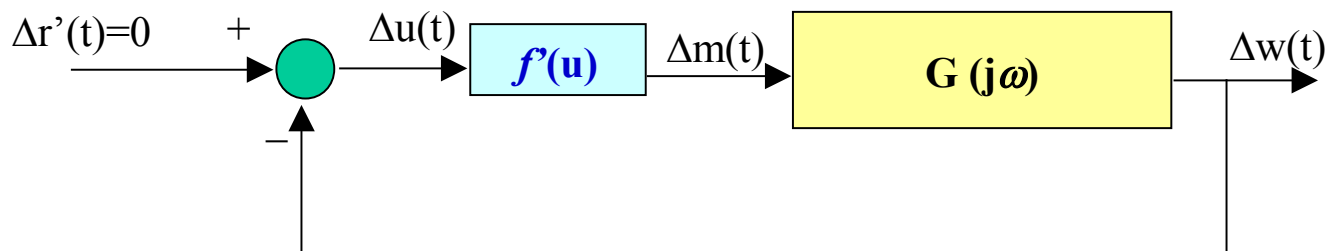

Such an assumption is usually taken for the sake of simplicity, and it can be relaxed

Fourier expansion - *Recall*

Consider a periodic function

$$y(t) = f(t), \quad y(t) = y(t - T), \quad T \text{ is a real constant}$$



$$y(t) = \frac{a_0}{2} + \sum_{k=1}^{\infty} \left(a_k \sin\left(k \frac{2\pi}{T} t\right) + b_k \cos\left(k \frac{2\pi}{T} t\right) \right)$$

$$a_k = \frac{2}{T} \int_{-T/2}^{T/2} f(t) \cos\left(k \frac{2\pi}{T} t\right) dt = \frac{1}{\pi} \int_{-\pi/2}^{\pi/2} f(t) \cos\left(k \frac{2\pi}{T} t\right) d\left(\frac{2\pi}{T} t\right)$$

$$k = 0, 1, 2, \dots \quad b_0 = 0$$

$$b_k = \frac{2}{T} \int_{-T/2}^{T/2} f(t) \sin\left(k \frac{2\pi}{T} t\right) dt = \frac{1}{\pi} \int_{-\pi/2}^{\pi/2} f(t) \sin\left(k \frac{2\pi}{T} t\right) d\left(\frac{2\pi}{T} t\right)$$

Describing Function – *Harmonic balance*

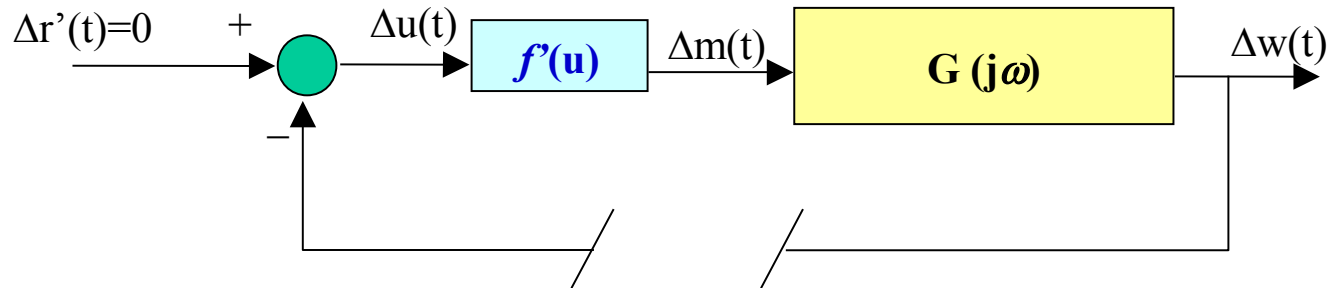

$$\Delta u(t) = U \sin(\bar{\omega}t)$$



$$m(t) = \sum_{k=1}^{\infty} (a_k \cos(k\bar{\omega}t) + b_k \sin(k\bar{\omega}t))$$



$$\Delta w(t) = \sum_{k=1}^{\infty} G_k (a_k \cos(k\bar{\omega}t + \varphi_k) + b_k \sin(k\bar{\omega}t + \varphi_k))$$

$$G_k = |G(jk\bar{\omega})| \quad \varphi_k = \angle G(jk\bar{\omega})$$

Describing Function – *Harmonic balance*

Consider the polar representation of a complex number associated with the exponential form of harmonic signals

$$\Delta u(t) = U e^{j\bar{\omega}t}$$

$$m(t) = \sum_{k=1}^{\infty} M_k e^{j\vartheta_k} e^{jk\bar{\omega}t}$$
$$M_k = \sqrt{a_k^2 + b_k^2}$$
$$\vartheta_k = \arctan \frac{a_k}{b_k}$$

Taking into account the low-pass property of the linear part of the system

$$\Delta w(t) = \sum_{k=1}^{\infty} G_k e^{j\varphi_k} M_k e^{j\vartheta_k} e^{jk\bar{\omega}t} \cong G_1 e^{j\varphi_1} M_1 e^{j\vartheta_1} e^{j\bar{\omega}t}$$

Describing Function – *Harmonic balance*

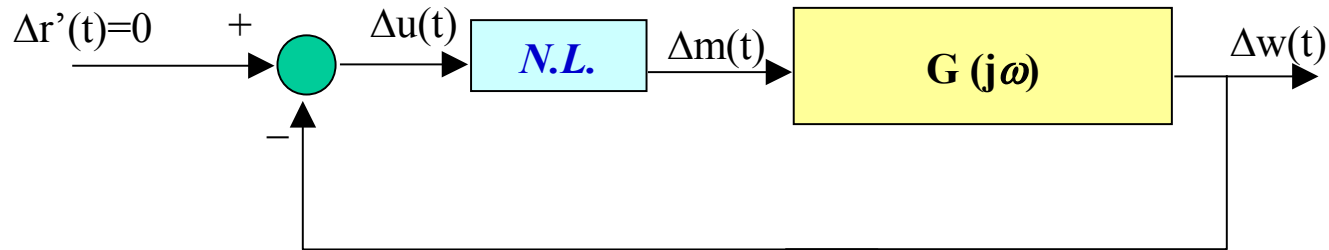

A permanent oscillation in the loop appears if $\Delta u(t) = -\Delta w(t)$

$$Ue^{j\bar{\omega}t} = -G_1 e^{j\varphi_1} M_1 e^{j\vartheta_1} e^{j\bar{\omega}t} \quad \longrightarrow \quad 1 + G_1 e^{j\varphi_1} \frac{M_1}{U} e^{j\vartheta_1} = 0$$

Harmonic balance equation

$$1 + G(j\omega)N(U, \omega) = 0$$

$$N(U, \omega) = \frac{1}{U} (b_1 + ja_1) \quad \text{is the Describing Function of the nonlinear term}$$

Describing Function – *Harmonic balance*

The harmonic balance equation is a **necessary condition** for the existence of limit cycles in the nonlinear system

The **approximate** analysis gives good estimates if the low-pass filter hypothesis is strongly verified. It is a good tool for engineers

The harmonic balance equation is similar to the characteristic polynomial function, i.e. it leads to the Nyquist condition for closed-loop stability

The Describing Function is a linear approximation of the static nonlinearity limited to the first harmonic

In most cases the Describing Function is not a function of the frequency and this simplifies the verification of the harmonic balance equation by means of the Nyquist plot of the transfer function

$$G(j\omega) = -\frac{1}{N(U, \omega)}$$

Describing Function – *Harmonic balance*

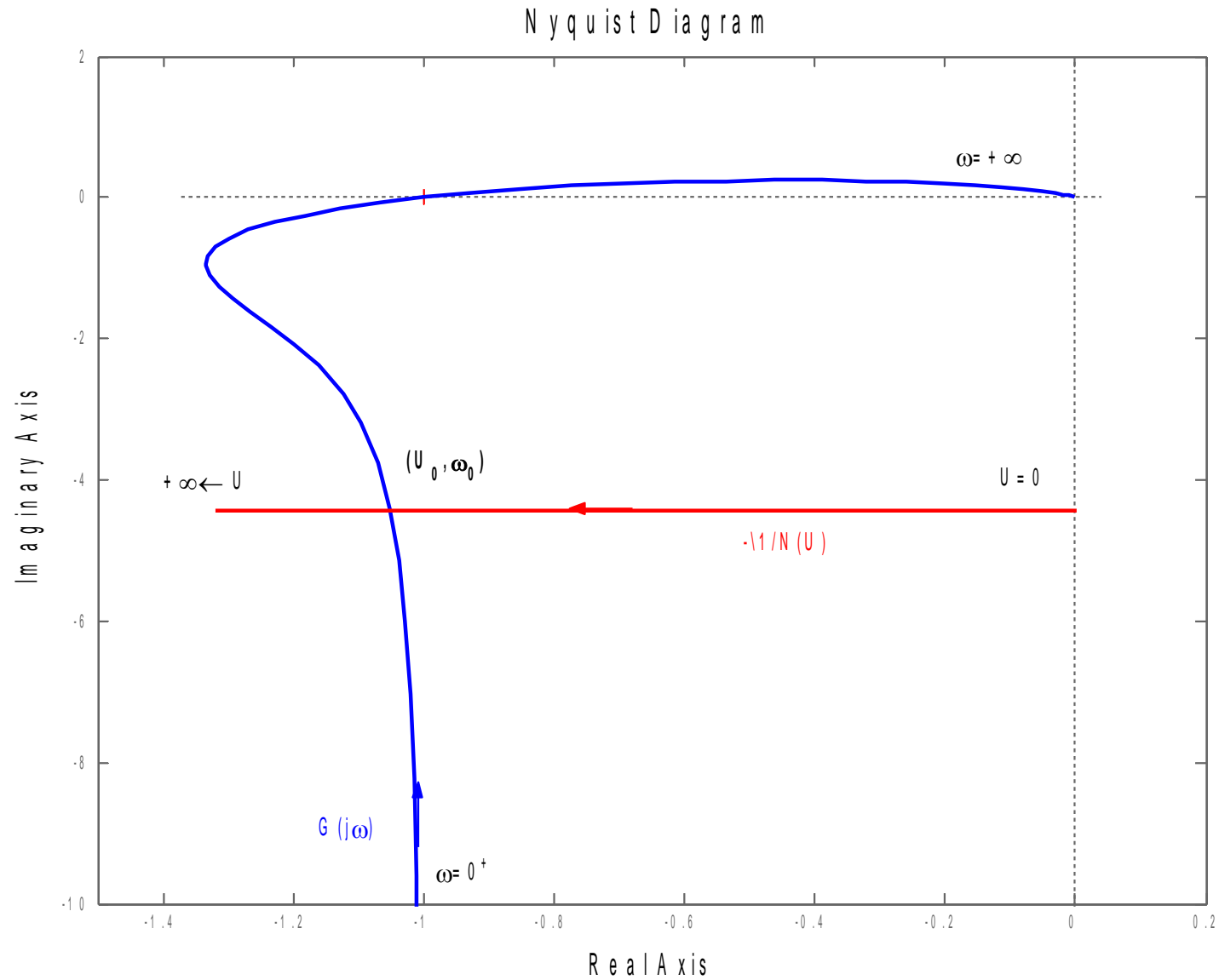

Describing Function – *Harmonic balance*

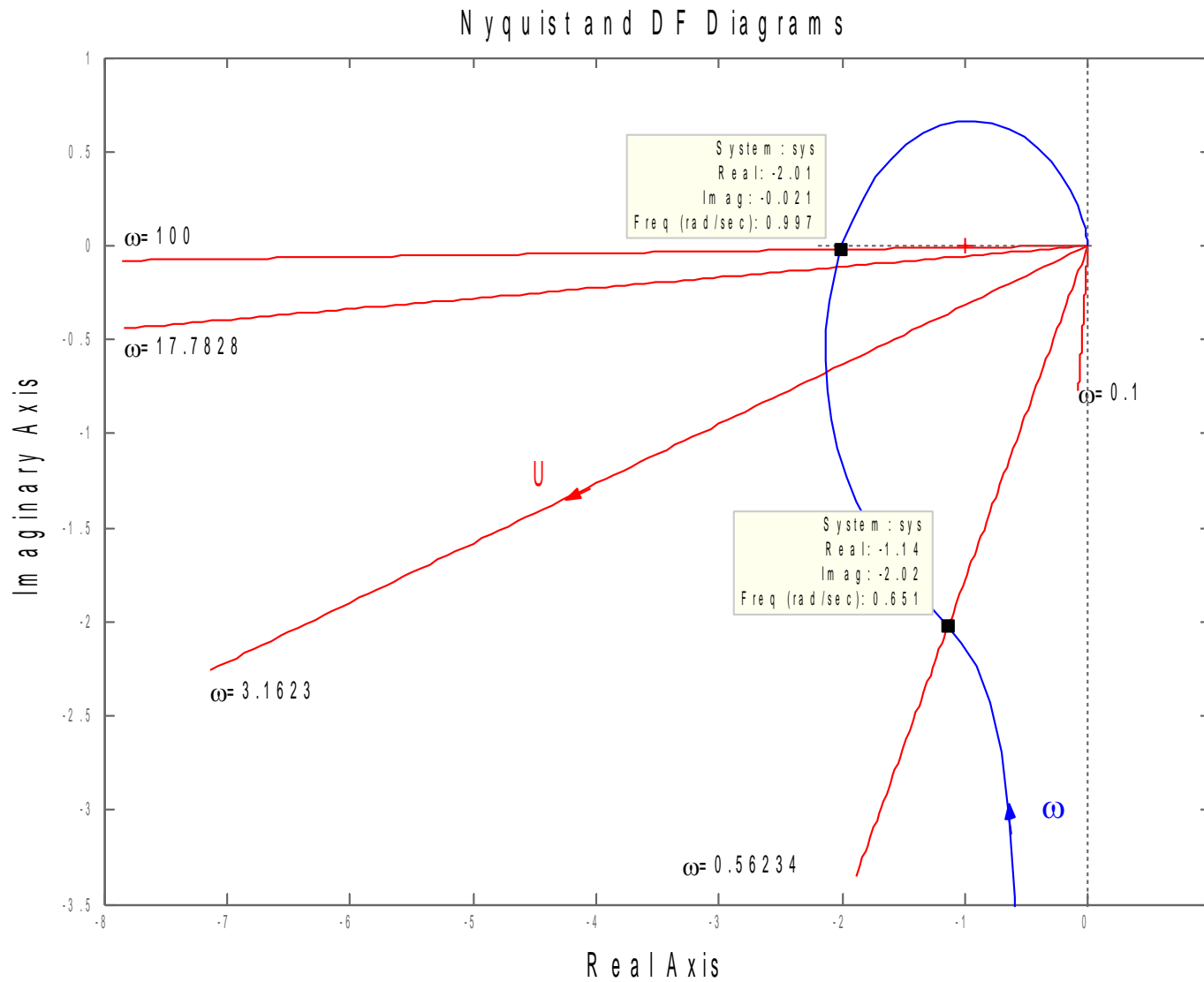

Describing Function – *Computation*

The DF computation can be performed by means of its definition

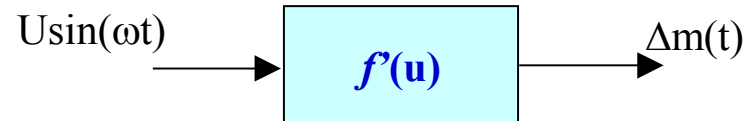

$$N(U, \omega) = \frac{1}{U} (b_1 + ja_1)$$

$$a_1 = \frac{2}{T} \int_{-T/2}^{T/2} \Delta m(t) \cos(\omega t) dt$$

$$b_1 = \frac{2}{T} \int_{-T/2}^{T/2} \Delta m(t) \sin(\omega t) dt$$

The evaluation of coefficients a_1 and b_1 can be performed by means of both analytical calculation and numerical integration, depending on the type of nonlinearity involved

Describing Function – Computation

Ideal relay

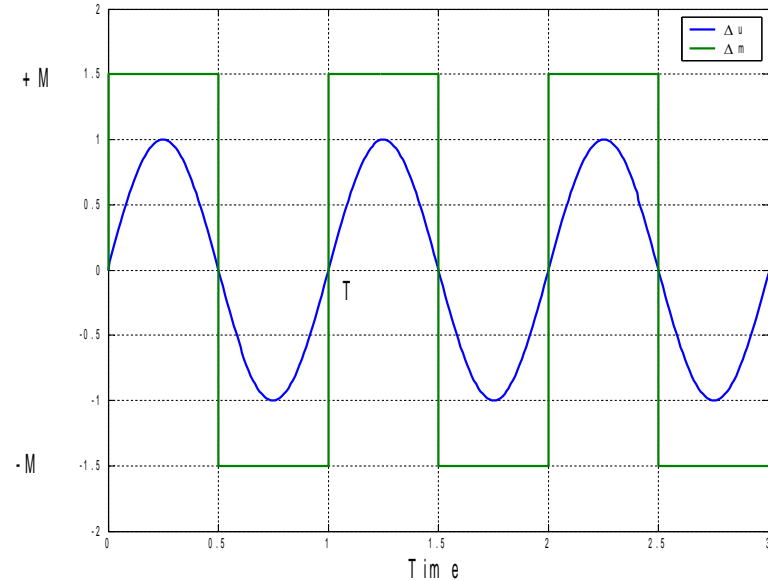
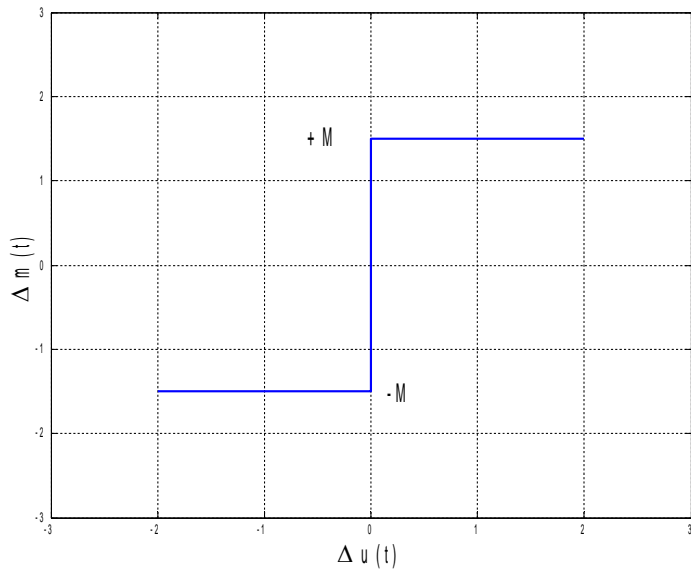

$$a_1 = \frac{2}{T} \int_{-T/2}^{T/2} \Delta m(t) \cos(\omega t) dt = 0$$

Because of the odd symmetry of the $\Delta m(t)$ signal

$$b_1 = \frac{2}{T} \int_{-T/2}^{T/2} \Delta m(t) \sin(\omega t) dt = \frac{2}{\pi} \int_0^{\pi/2} M \sin(\vartheta) d\vartheta = \frac{4M}{\pi}$$

$$N(U, \omega) = \frac{4M}{U\pi}$$

Describing Function – *Computation*

Ideal relay

The negative reciprocal of the DF is the negative real axis in backward direction

A limit cycle can exist if the relative degree of $G(j\omega)$ is greater than two

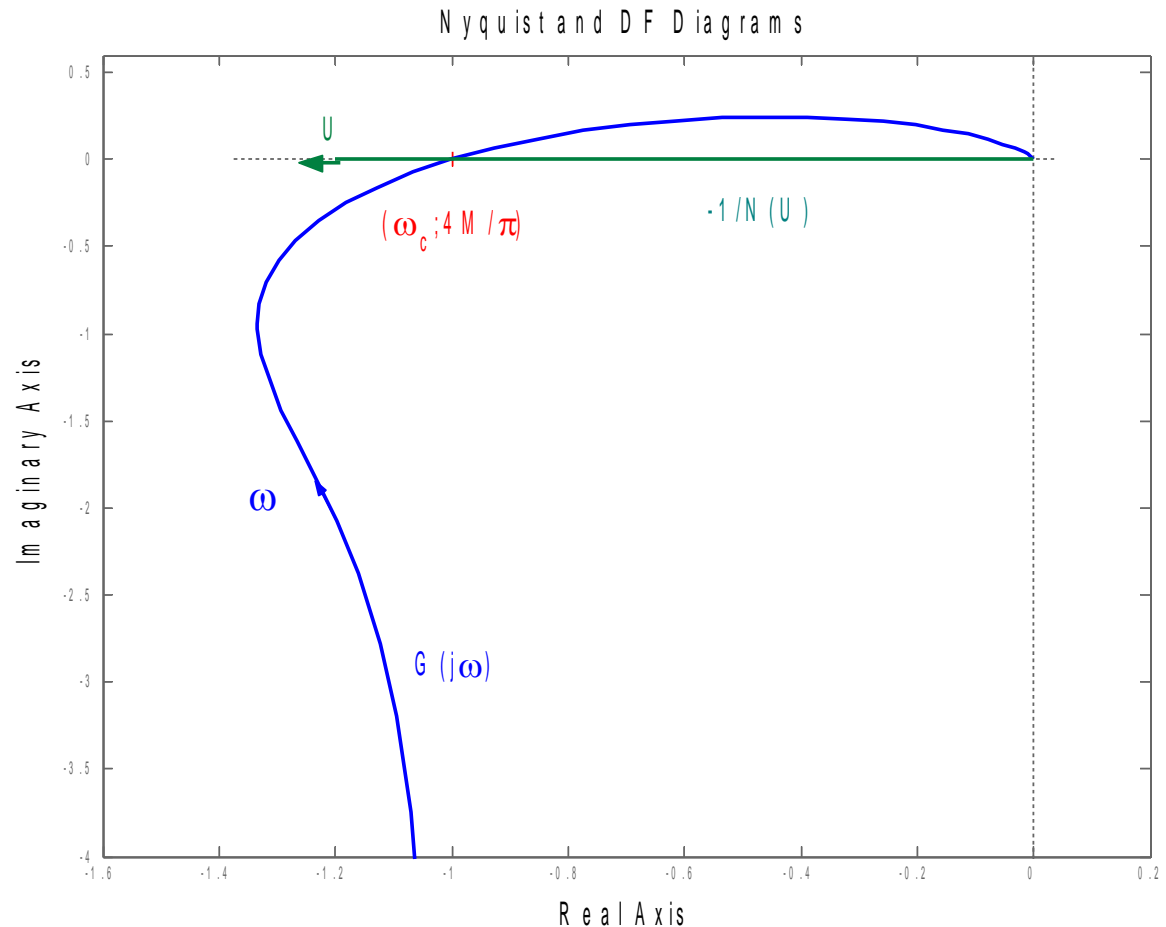

The oscillation frequency is the critical frequency ω_c of the linear system and the oscillation's magnitude is proportional to the relay gain M

Describing Function – Computation

Pure hysteresis

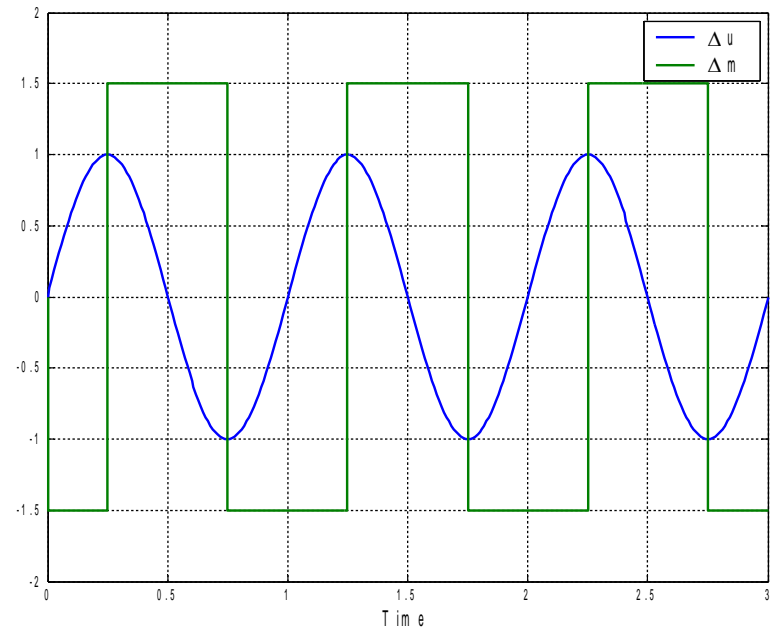
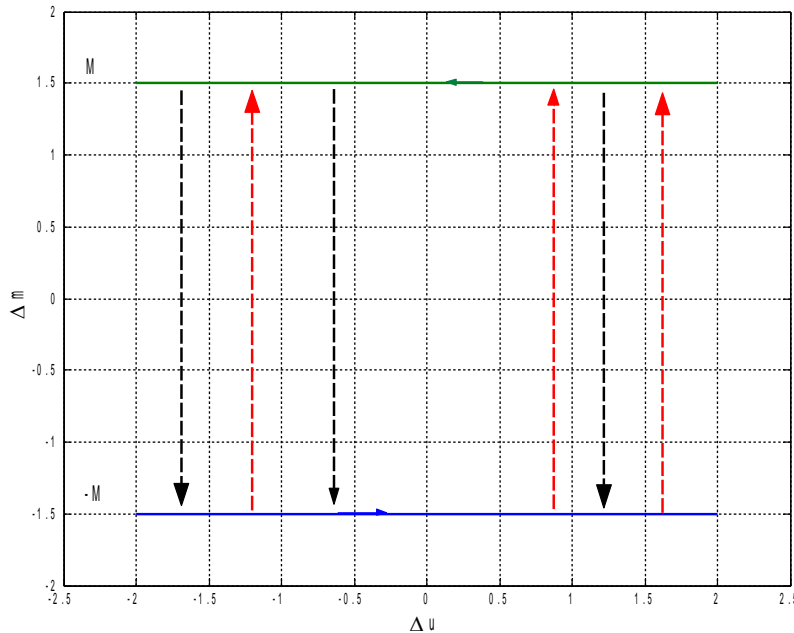

$$b_1 = \frac{2}{T} \int_{-T/2}^{T/2} \Delta m(t) \sin(\omega t) dt = 0$$

Because of the even symmetry of the $\Delta m(t)$ signal

$$a_1 = \frac{2}{T} \int_{-T/2}^{T/2} \Delta m(t) \cos(\omega t) dt = -\frac{2}{\pi} \int_0^{\pi/2} M \cos(\vartheta) d\vartheta = -\frac{4M}{\pi}$$

$$N(U, \omega) = -j \frac{4M}{U\pi}$$

Describing Function – *Computation*

Pure hysteresis

The negative reciprocal of the DF is the negative imaginary axis in backward direction

A limit cycle can exist if the relative degree of $G(j\omega)$ is greater than one and $G(j\omega)$ is a type-0 system

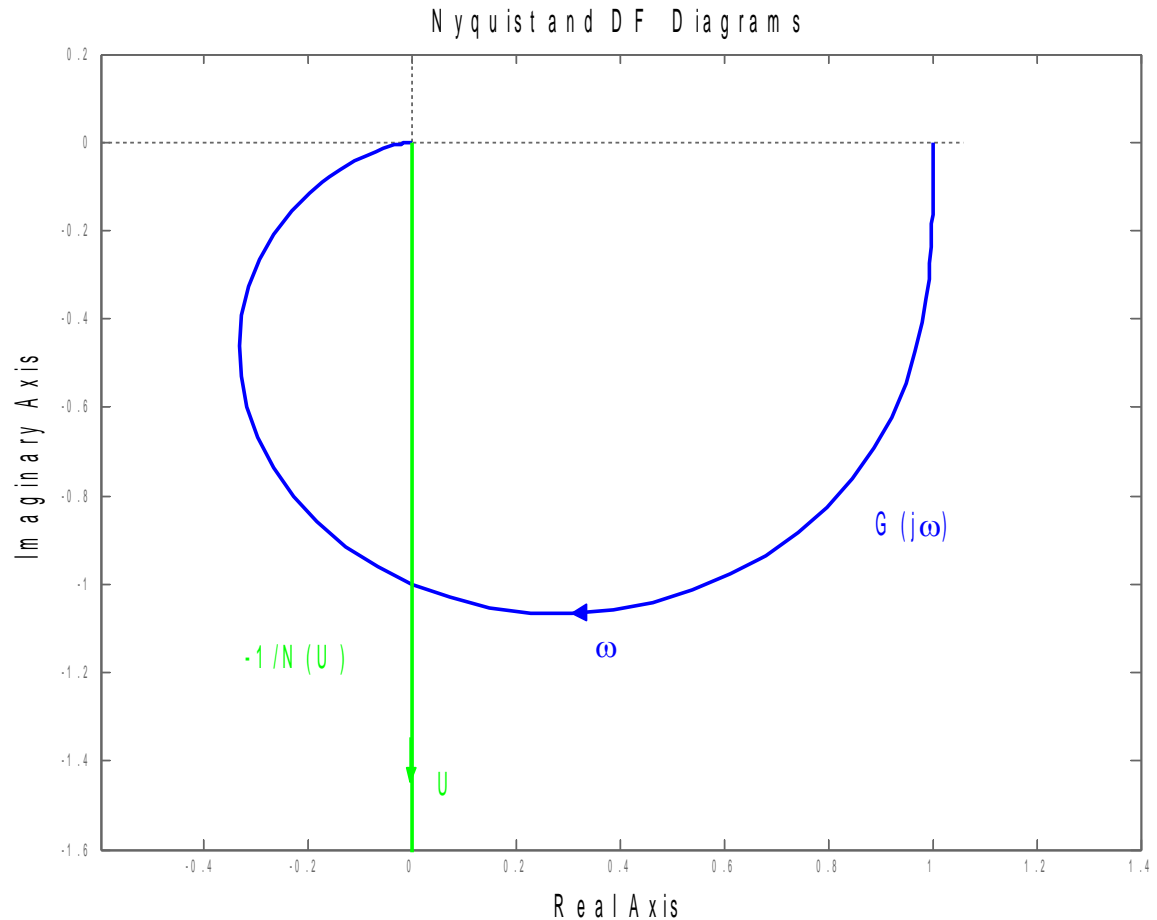

The oscillation frequency is lower than the critical frequency ω_c of the linear system and the oscillation's magnitude is proportional to the relay gain M and to the modulus of the transfer function at phase $-\pi/4$

Describing Function – Computation

Hysteretic relay

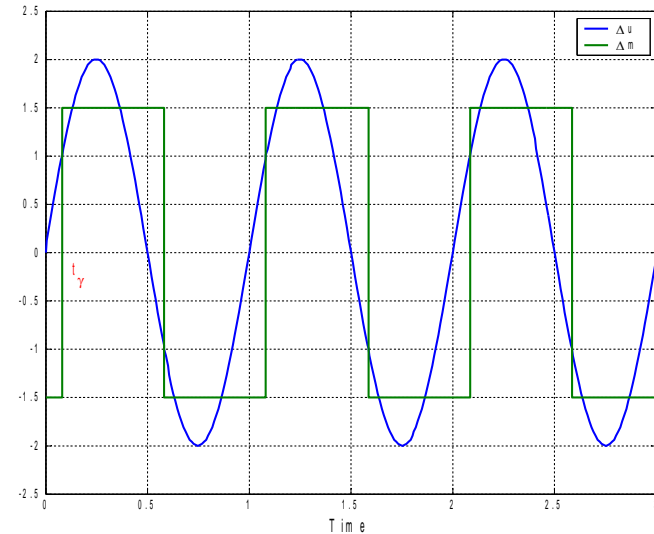
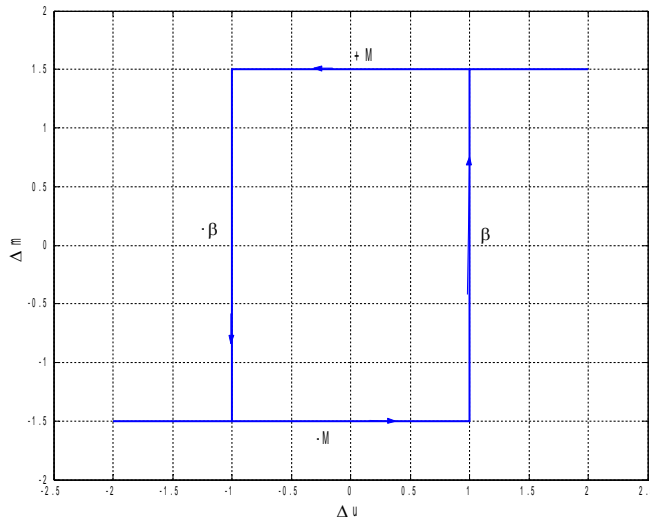

If $U \leq \beta$ the hysteretic relay behaves as pure hysteresis

$$b_1 = -M \frac{8}{T} \int_0^{t_\gamma} \sin(\omega t) dt + M \frac{8}{T} \int_{t_\gamma}^{T/4} \sin(\omega t) dt = \frac{4M}{\pi} \sqrt{1 - \left(\frac{\beta}{U}\right)^2}$$

$$a_1 = -M \frac{8}{T} \int_0^{t_\gamma} \cos(\omega t) dt + M \frac{8}{T} \int_{t_\gamma}^{T/4} \cos(\omega t) dt =$$

$$N(U, \omega) = \begin{cases} -j \frac{4M}{U\pi} & U \leq \beta \\ \frac{4M}{\pi U} \sqrt{1 - \left(\frac{\beta}{U}\right)^2} - j \frac{4M\beta}{\pi U^2} & U > \beta \end{cases}$$

The imaginary part of $N(U)$ is proportional to the hysteresis area

Describing Function – *Computation*

Hysteretic relay

The negative reciprocal of the DF is the parallel to the negative real axis and with constant negative imaginary part

If β is larger than U the relay could not behave as a pure hysteresis

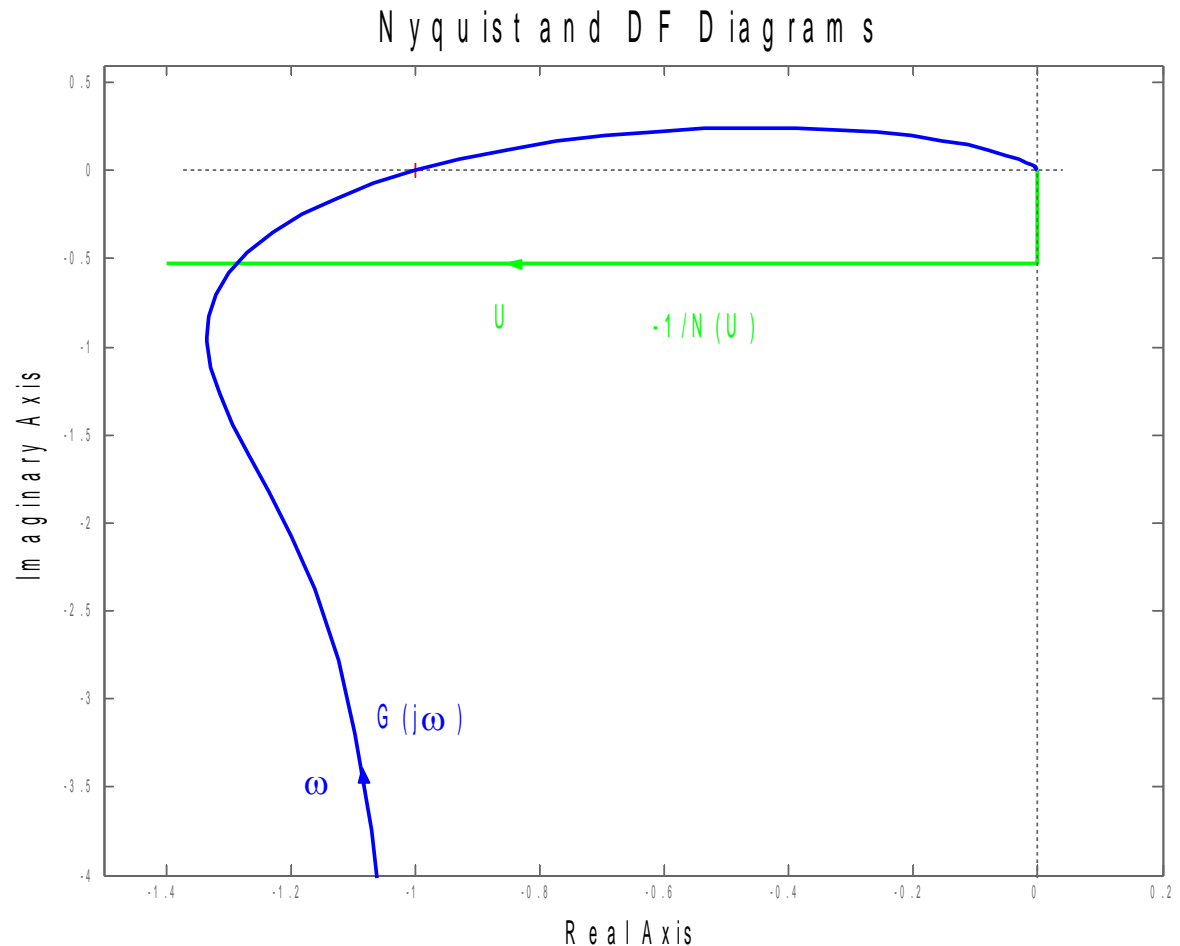

The oscillation frequency is lower than the critical frequency ω_c of the linear system and the oscillation's magnitude is proportional to the relay gain M

Describing Function – Computation

Saturation

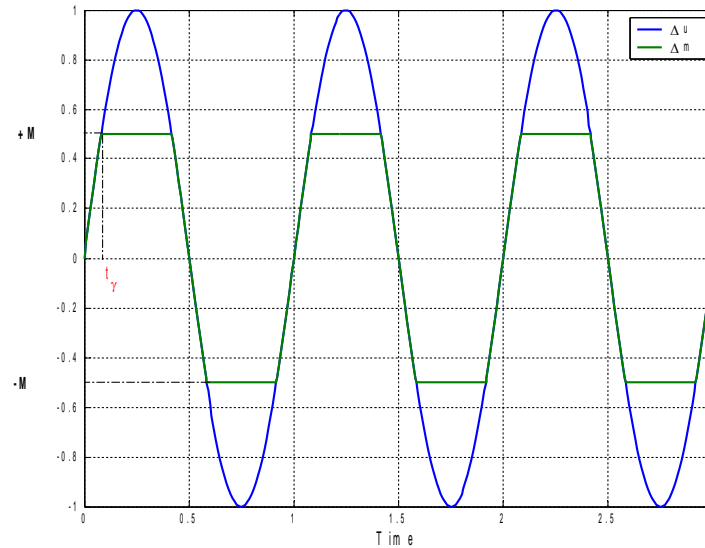
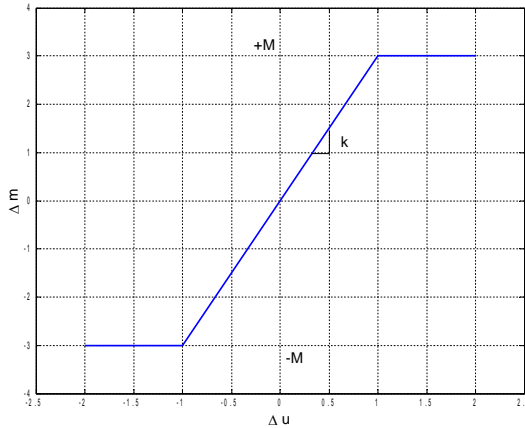

If $U \leq M$ the saturation behaves as pure gain

$$a_1 = \frac{2}{T} \int_{-T/2}^{T/2} \Delta m(t) \cos(\omega t) dt = 0$$

Because of the odd symmetry of the $\Delta m(t)$ signal

$$b_1 = \frac{8}{T} \int_0^{t_y} kU \sin^2(\omega t) dt + M \frac{8}{T} \int_{t_y}^{T/4} \sin(\omega t) dt = \frac{2kU}{\pi} \left[\arcsin\left(\frac{M}{kU}\right) + \left(\frac{M}{kU}\right) \sqrt{1 - \left(\frac{M}{kU}\right)^2} \right]$$

$$N(U) = \begin{cases} k & U \leq \frac{M}{k} \\ \frac{2k}{\pi} \left[\arcsin\left(\frac{M}{kU}\right) + \left(\frac{M}{kU}\right) \sqrt{1 - \left(\frac{M}{kU}\right)^2} \right] & U > \frac{M}{k} \end{cases}$$

Describing Function – *Computation*

Saturation

The negative reciprocal of the DF is part of the negative real axis in backward direction

A limit cycle can exist if the relative degree of $G(j\omega)$ is greater than two and gain k is sufficiently high

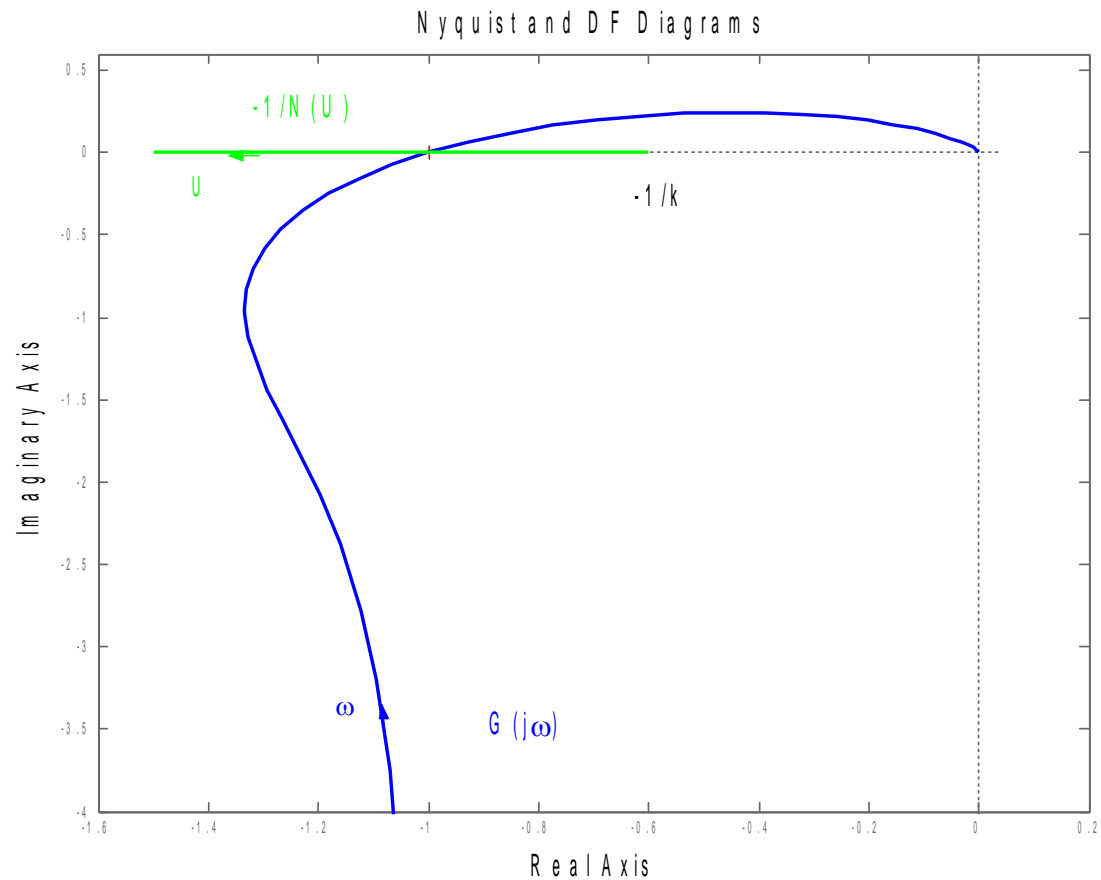

The oscillation frequency is the critical frequency ω_c of the linear system and the oscillation's magnitude depends on the saturation parameters M and k

Describing Function – Computation

Dead zone

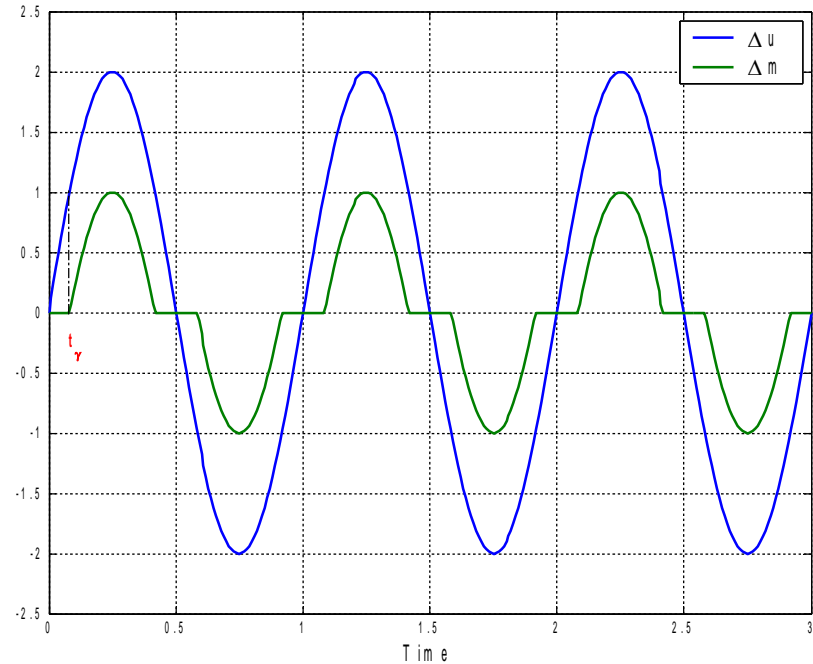
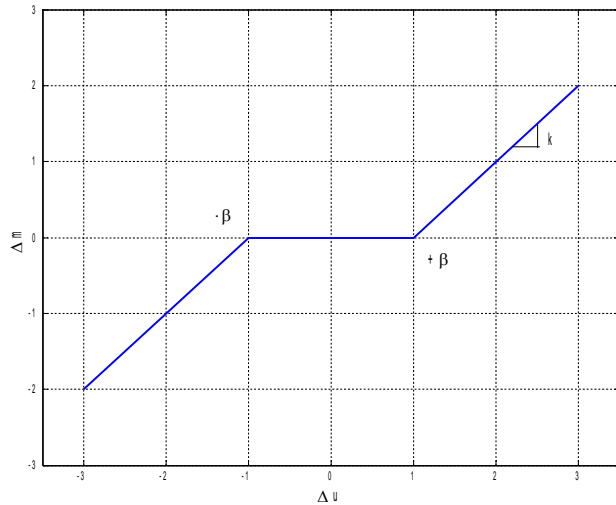

If $U \leq \beta$ the dead zone has no output

$$a_1 = \frac{2}{T} \int_{-T/2}^{T/2} \Delta m(t) \cos(\omega t) dt = 0$$

Because of the odd symmetry of the $\Delta m(t)$ signal

$$b_1 = \frac{8}{T} \int_{t_\gamma}^{T/4} k(U \sin(\omega t) - \beta) \sin(\omega t) dt = \frac{2kU}{\pi} \left[\frac{\pi}{2} - \arcsin\left(\frac{\beta}{U}\right) - \left(\frac{\beta}{U}\right) \sqrt{1 - \left(\frac{\beta}{U}\right)^2} \right]$$

$$\beta = U \sin(\omega t_\gamma)$$

$$N(U) = \begin{cases} 0 & U \leq \beta \\ k - \frac{2k}{\pi} \left[\arcsin\left(\frac{\beta}{U}\right) + \left(\frac{\beta}{U}\right) \sqrt{1 - \left(\frac{\beta}{U}\right)^2} \right] & U > \beta \end{cases}$$

Describing Function – *Computation*

Dead zone

The negative reciprocal of the DF is part of the negative real axis in forward direction

A limit cycle can exist if the relative degree of $G(j\omega)$ is greater than two and gain k is sufficiently high

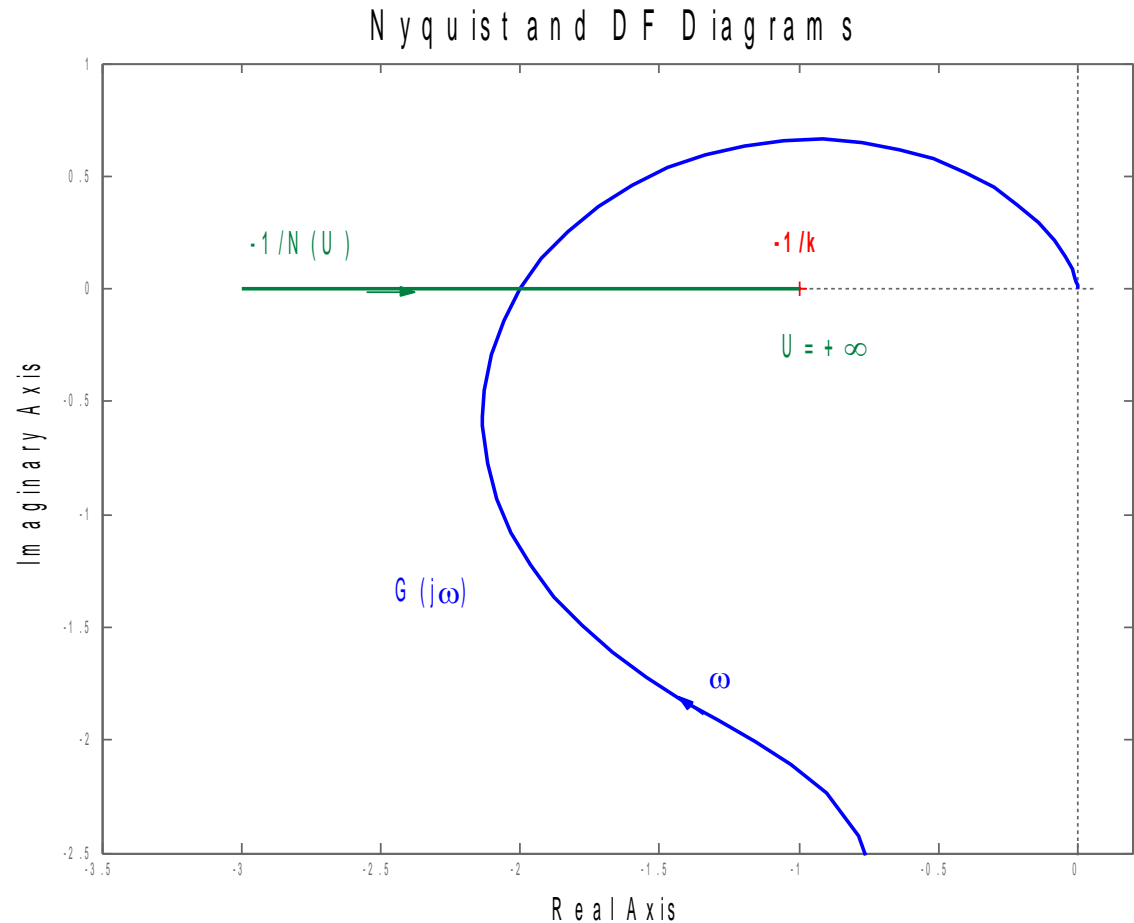

The oscillation frequency is the critical frequency ω_c of the linear system and the oscillation's magnitude depends on the dead zone parameters β and k

Describing Function – *Computation*

Dead zone

The nonlinear characteristics of the Dead Zone can be computed by subtracting the Saturation characteristics from a linear one

$$\Psi(\Delta u) = k - \Phi(\Delta u)$$

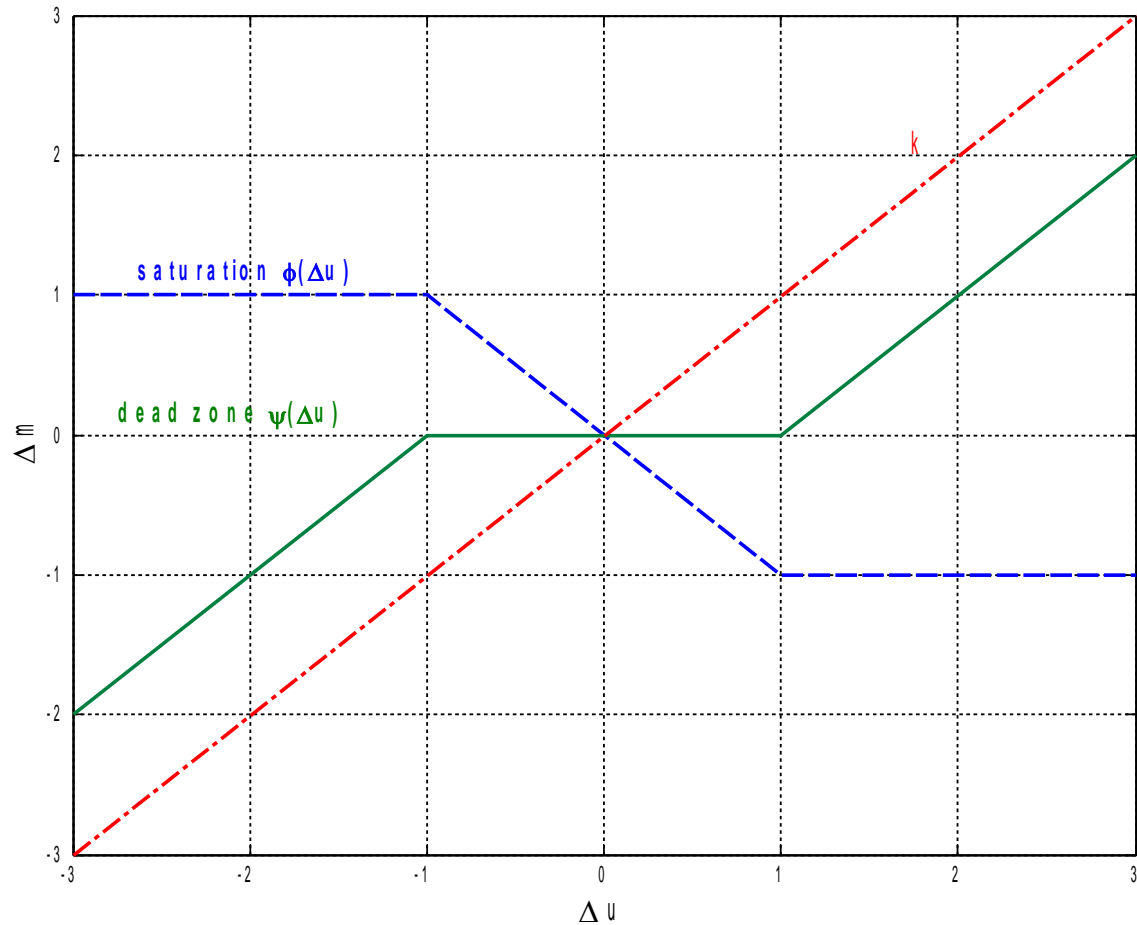

$$N_{\Psi}(U) = k - N_{\Phi}(U)$$

Describing Function – *Computation*

The Describing function of a nonlinear characteristics can be computed as the combination of the Describing Functions of the elementary constituting nonlinear characteristics

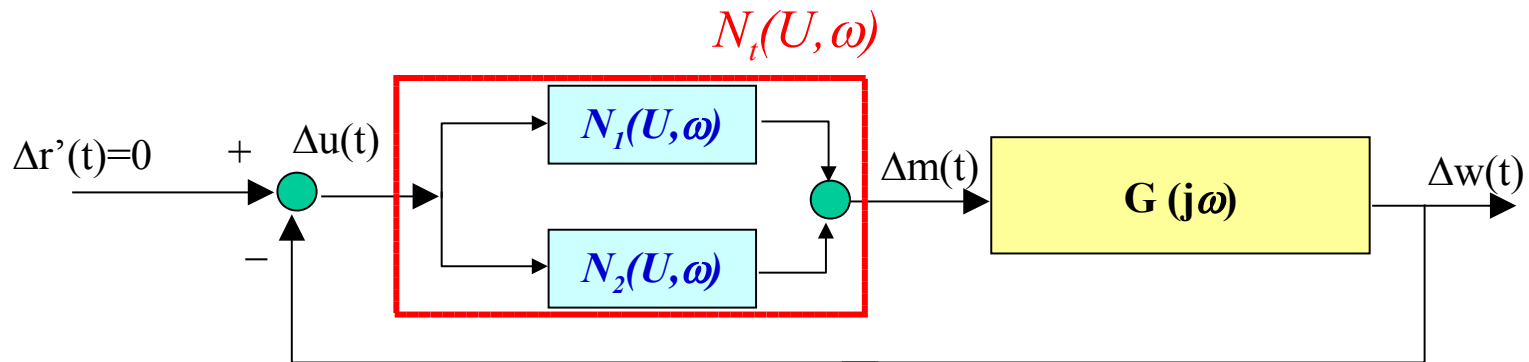

$$N_t(U) = N_1(U) + N_2(U)$$

Describing Function – *Computation*

A number of Describing Function can be computed by particularisation of the function

$$\Phi(\alpha) = \frac{2}{\pi} \left[\arcsin(\alpha) + \alpha \sqrt{1 - \alpha^2} \right]$$

in which the parameter α defines a peculiar point of the nonlinear characteristics

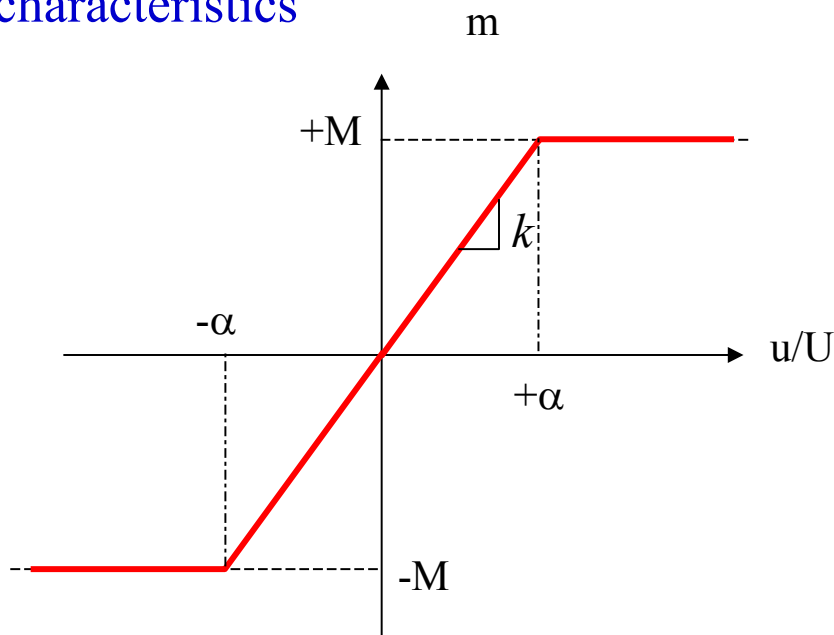

$$N(\alpha) = \begin{cases} k & \alpha \geq 1 \\ k \cdot \Phi(\alpha) & \alpha < 1 \end{cases}$$

Describing Function – *Computation*

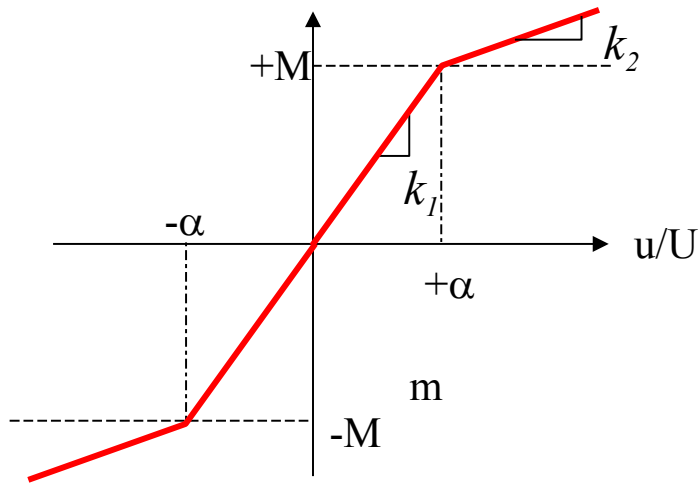

$$N(\alpha) = \begin{cases} k_1 & \alpha \geq 1 \\ k_2 + (k_1 - k_2) \cdot \Phi(\alpha) & \alpha < 1 \end{cases}$$

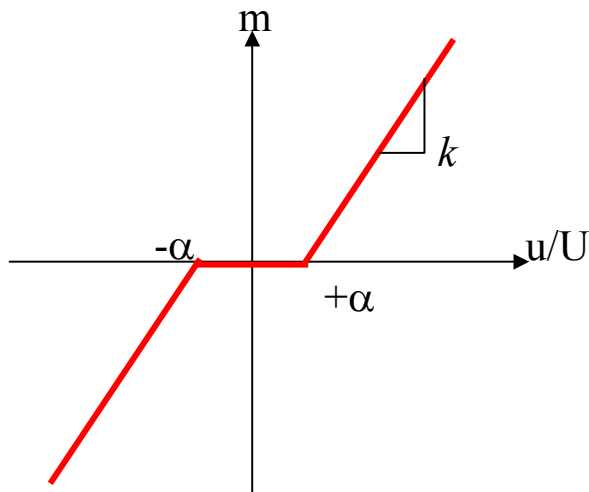

$$N(\alpha) = \begin{cases} 0 & \alpha \geq 1 \\ k(1 - \Phi(\alpha)) & \alpha < 1 \end{cases}$$

Describing Function – Computation

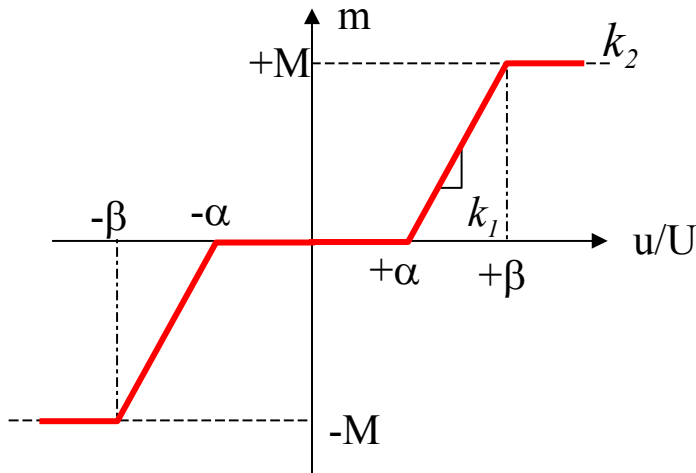

$$N(\alpha) = \begin{cases} 0 & \alpha \geq 1 \\ k \cdot (1 - \Phi(\alpha)) & \alpha < 1 \leq \beta \\ k \cdot (\Phi(\beta) - \Phi(\alpha)) & \beta < 1 \end{cases}$$

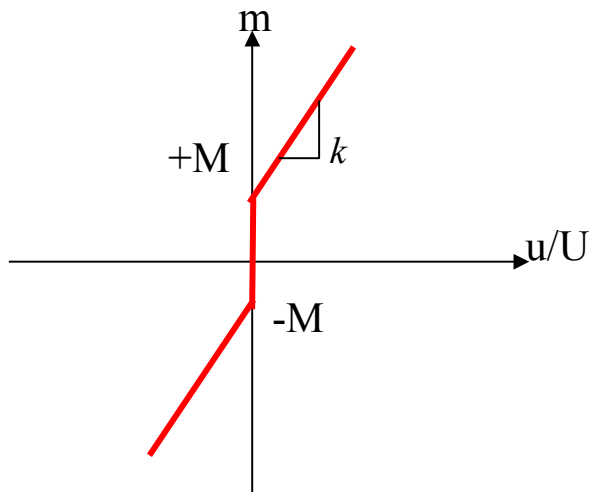

$$N(\alpha) = k + \frac{4M}{\pi}$$

Describing Function – *Computation*

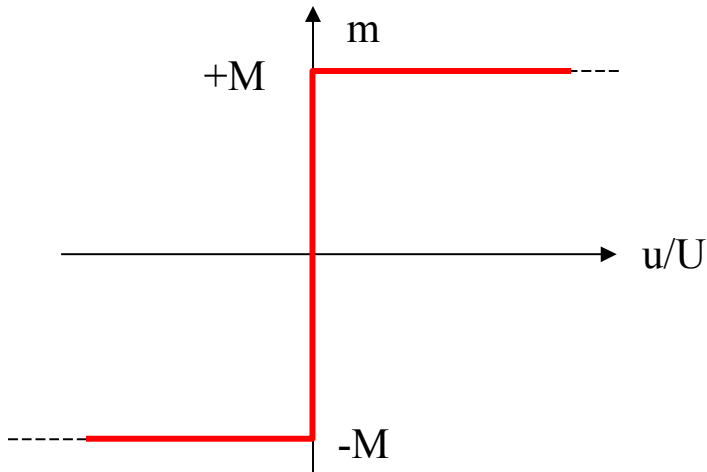

$$N(\alpha) = \frac{4M}{\pi}$$

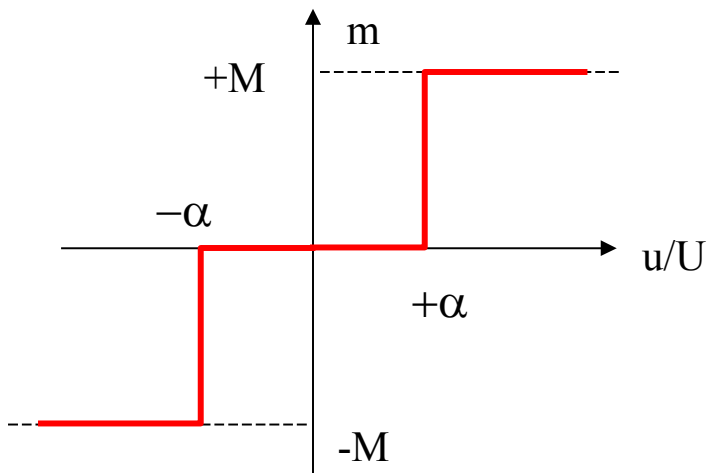

$$N(\alpha) = \begin{cases} 0 & \alpha \geq 1 \\ \frac{4M}{\pi} \sqrt{1 - \alpha^2} & \alpha < 1 \end{cases}$$

Describing Function – *Computation*

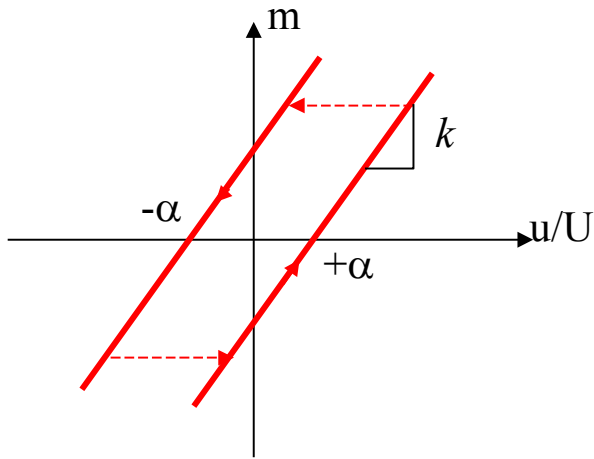

$$N(\alpha) = \begin{cases} 0 & \alpha \geq 1 \\ \frac{k}{2} [1 - \Phi(2\alpha - 1)] - j \frac{4k\alpha}{\pi} (1 - \alpha) & \alpha < 1 \end{cases}$$

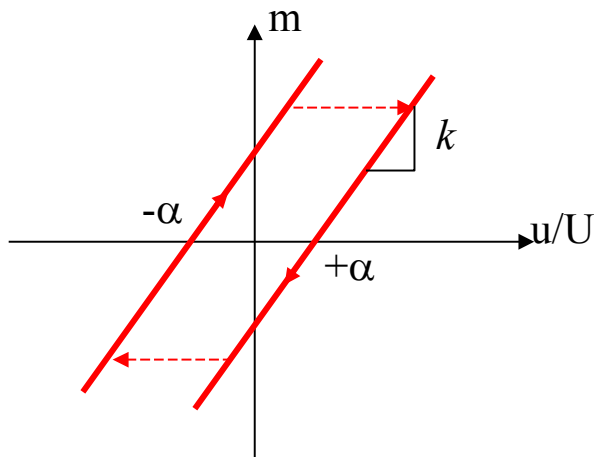

$$N(\alpha) = \begin{cases} 0 & \alpha \geq 1 \\ \frac{k}{2} [1 - \Phi(2\alpha - 1)] + j \frac{4k\alpha}{\pi} (1 - \alpha) & \alpha < 1 \end{cases}$$

Describing Function – *Computation*

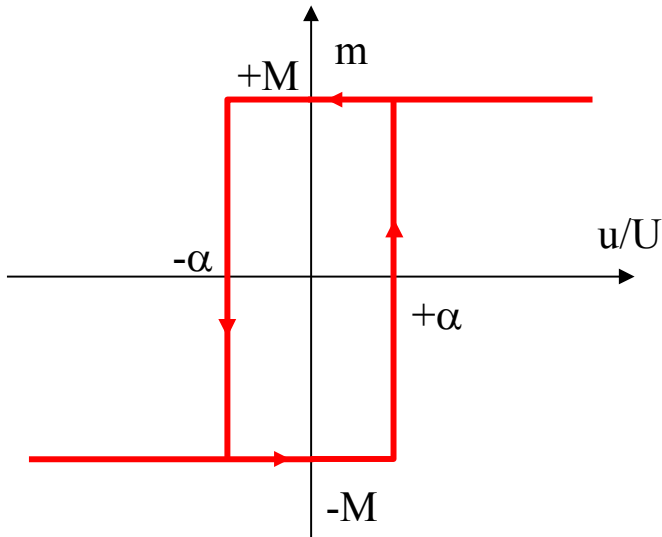

$$N(U, \omega) = \begin{cases} 0 & \alpha \geq 1 \\ \frac{4M}{\pi U} \sqrt{1 - \alpha^2} - j \frac{4M\alpha}{\pi U} & \alpha < 1 \end{cases}$$

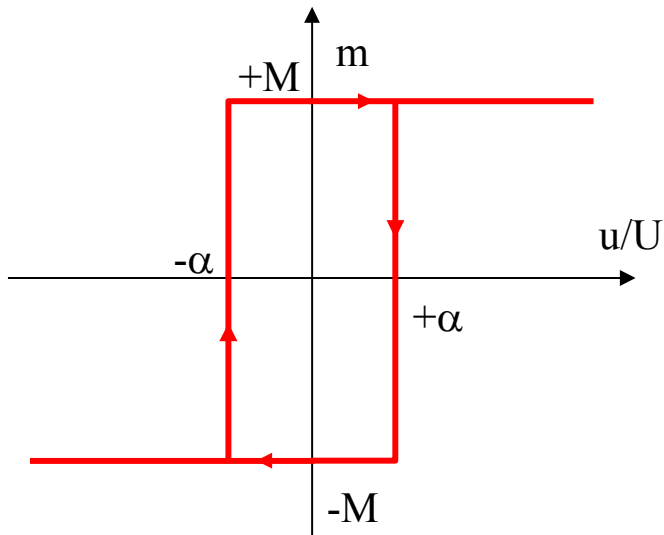

$$N(U, \omega) = \begin{cases} 0 & \alpha \geq 1 \\ \frac{4M}{\pi U} \sqrt{1 - \alpha^2} + j \frac{4M\alpha}{\pi U} & \alpha < 1 \end{cases}$$

Describing Function – Computation

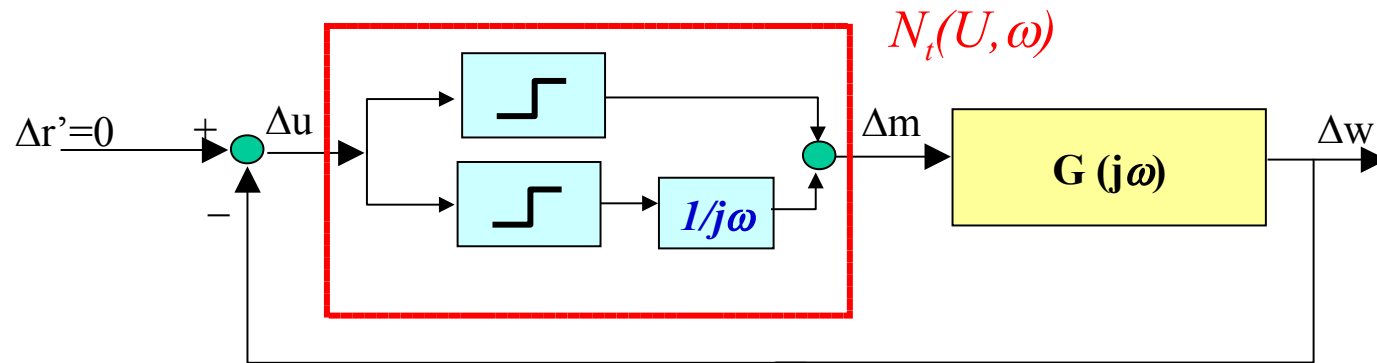

$$N_t(U) = N_1(U) + N_1(U) \frac{1}{j\omega}$$

$$N(U, \omega) = \frac{4M}{\pi U} - j \frac{4M}{\pi U \omega}$$

$$\frac{-1}{N(U, \omega)} = -\frac{\pi U \omega}{4M(1 + \omega^2)} (\omega + j)$$

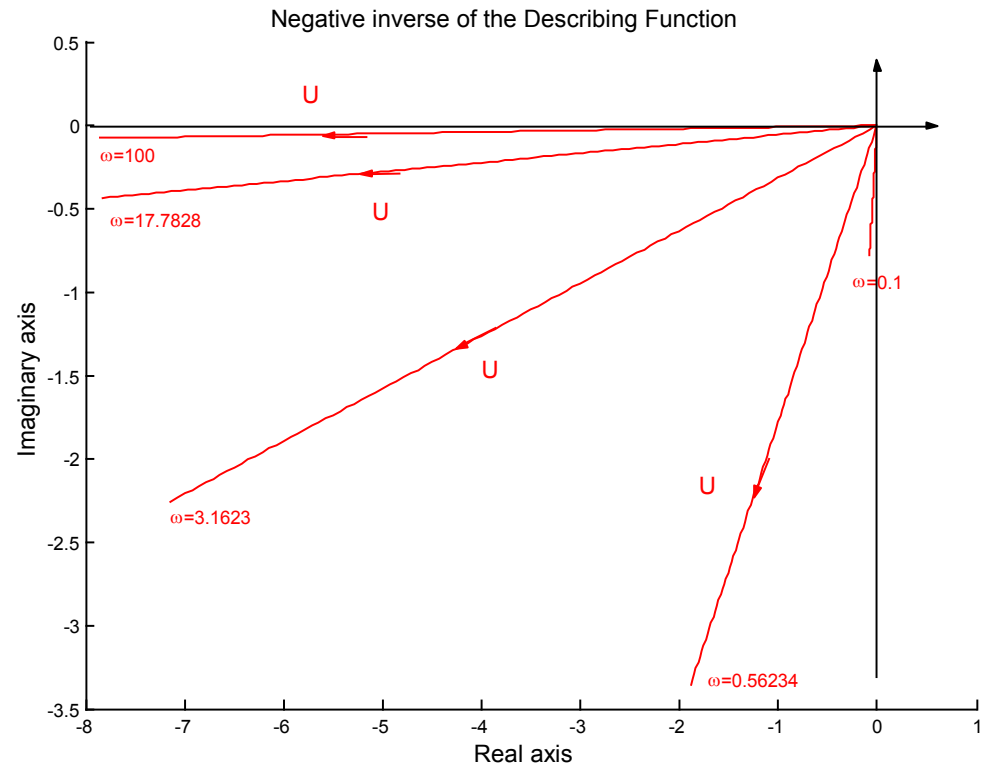

Stability of limit cycles

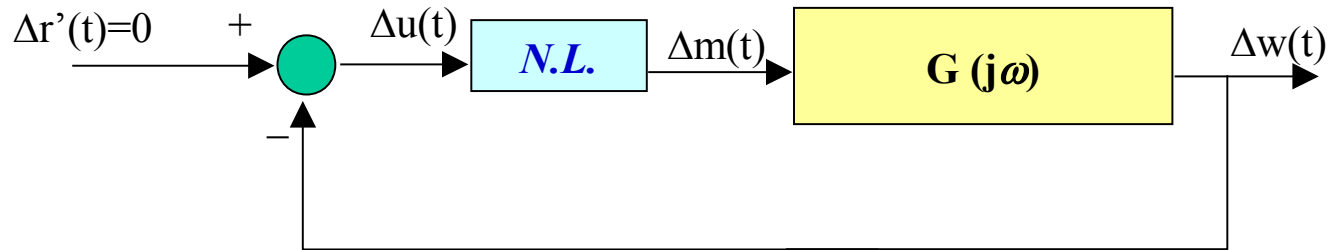

If the block $N.L.$ is a pure constant k , the stability of the feedback system can be performed by means of the **Nyquist criterion**, which gives the number of roots with positive real roots of the **Harmonic balance equation**

$$1 + G(j\omega)k = 0$$

The Nyquist criterion looks at the relative position of the transfer function $G(j\omega)$ with respect to the point $(-1/k, 0)$ in the complex plain.

By extension the criterion can be applied to any point $-\alpha$ of the complex plain with reference to the **Harmonic balance equation**

$$\alpha + G(j\omega) = 0, \quad \alpha \in C$$

Stability of limit cycles

If the transfer function $G(j\omega)$ represents a stable system, the reduced Nyquist criterion can be applied, i.e. the closed loop stability can be stated if the reference point $-\alpha$ of the complex plain remains on the left-side when running along the Nyquist plot of $G(j\omega)$ from $\omega=0^+$ to $\omega=+\infty$.

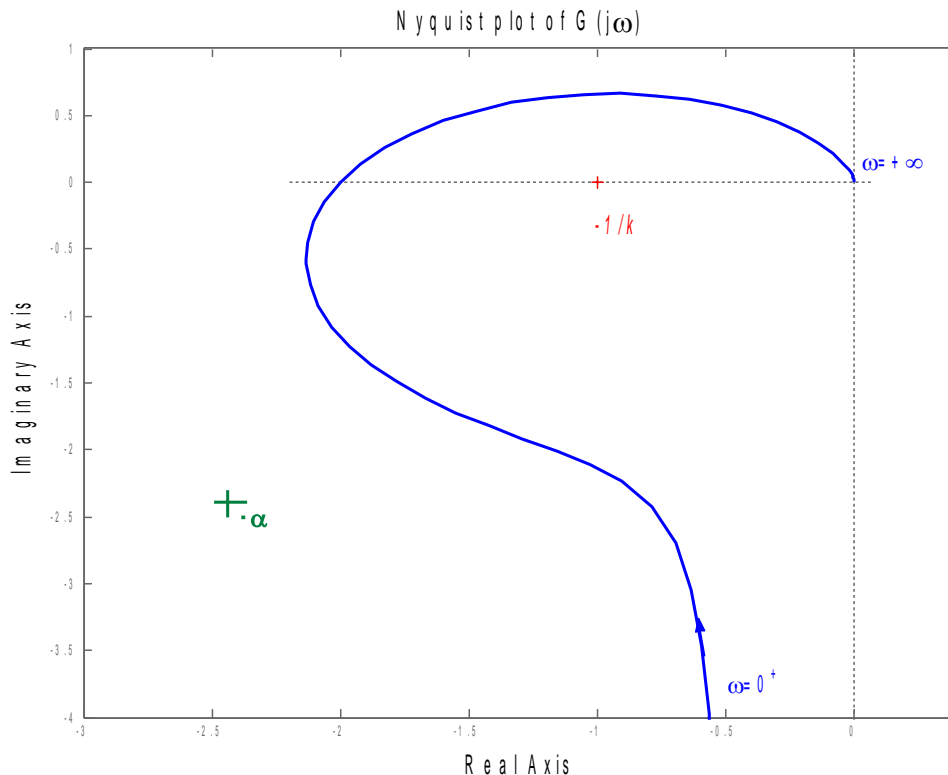

$$G(j\omega) = \frac{1}{j\omega((j\omega)^2 + 0.5j\omega + 1)}$$

The closed loop is not stable with respect to the point $(-1/k, 0)$.

The closed loop is stable with respect to the point $-\alpha$

Stability of limit cycles

Can the generalization of the Nyquist criterion be used to analyse the stability of a limit cycle?

YES

What does it mean that a limit cycle is stable?

If a perturbation of the magnitude of the periodic oscillation occurs, it tends to the original value as time passes.

How can be considered a limit cycle from the Nyquist criterion point of view?

It is a marginally stable condition.

How can the magnitude of a limit cycle be represented?

By a point in the Describing Function plot.

Stability of limit cycles

Points **B**, **B'**, **B''**, **A** and **A'** represent possible magnitudes of the oscillation.

A and **B** represent two possible limit cycles

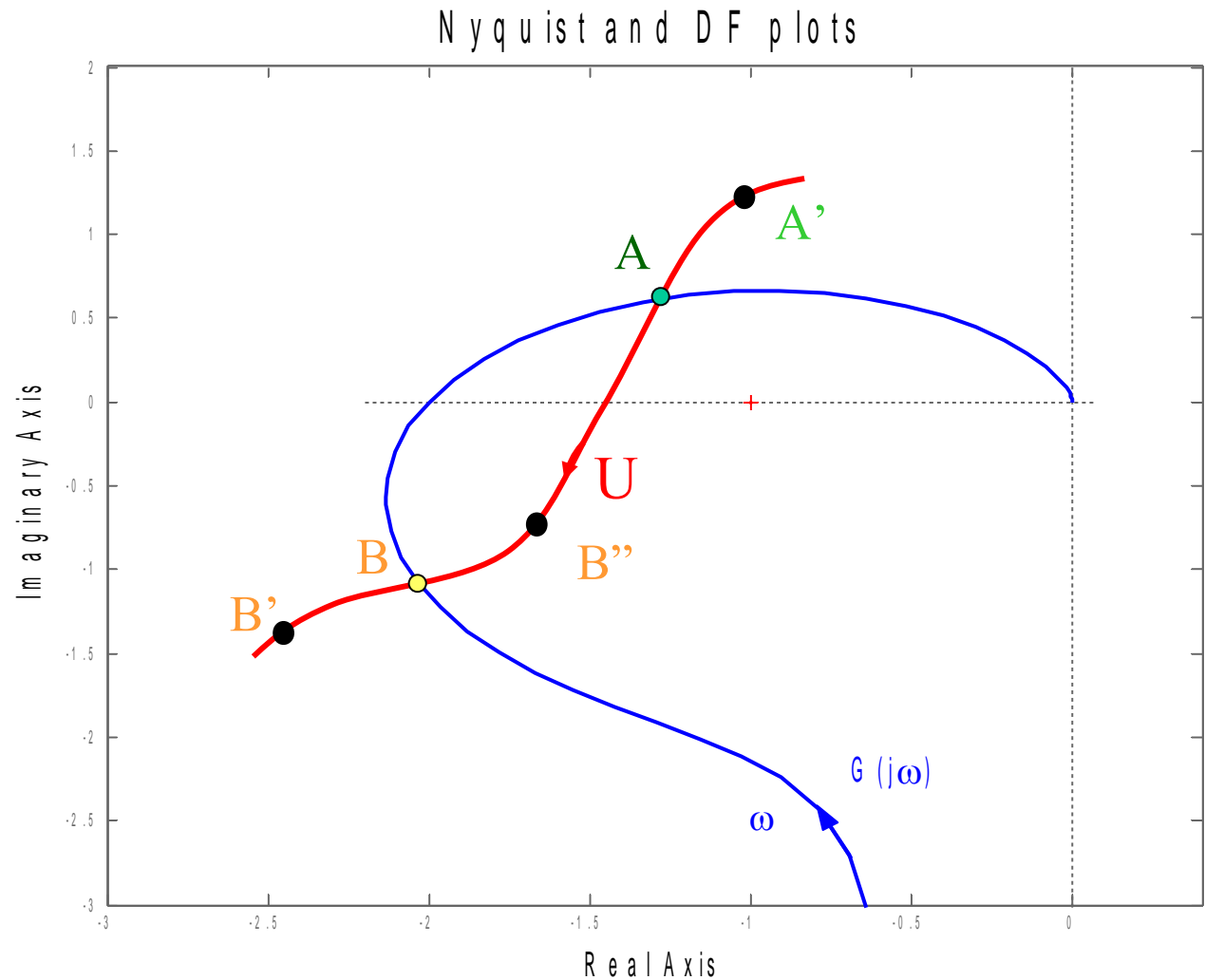

Stability of limit cycles

Applying the reduced Nyquist criterion with respect to:

point **B'**: oscillations tend to decrease (**stable system**)

point **B''**: oscillations tend to increase (**unstable system**)

point **A'**: oscillations tend to decrease (**stable system**)

B: Stable limit cycle

A: Unstable limit cycle

Nyquist and DF plots

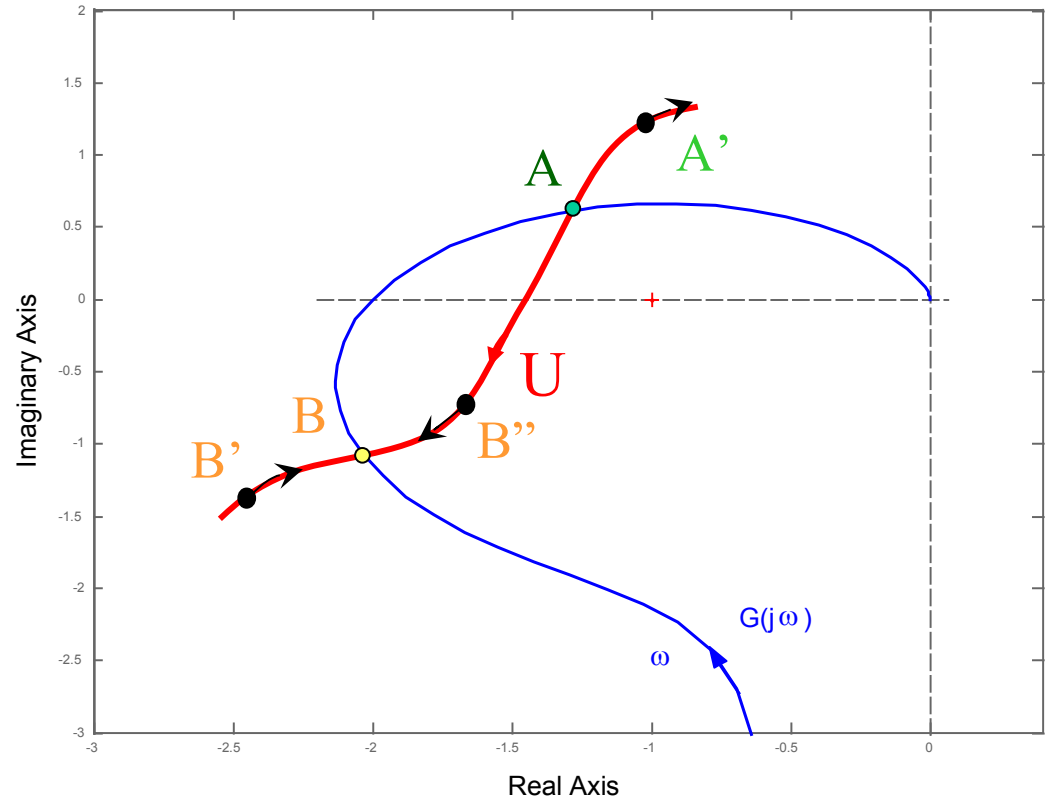

The linear system $G(j\omega)$ is assumed to be stable in order to apply the reduced Nyquist criterion

DF Analysis – *Example of application*

Consider a DC motor with permanent magnets

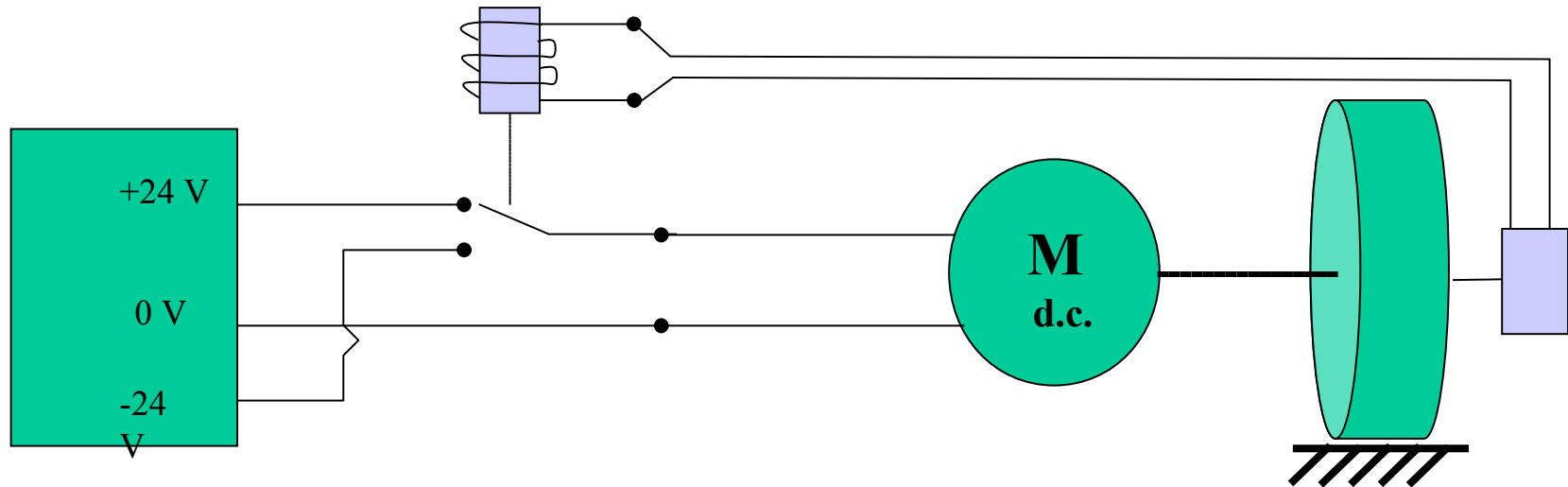

The position of the motor shaft is measured by means of a rotational variable resistance.

The voltage on the resistance drives the position of a relay that switches the motor supply voltage between +/- 24 V d.c.

DF Analysis – *Example of application*

The linear approximate model of a DC motor is the following

$$v_r(t) = R_r i_r(t) + L_r \frac{di_r(t)}{dt} + e(t)$$

$$J \frac{d\omega(t)}{dt} = C_{em}(t) + B\omega(t)$$

$$\omega = \frac{d\vartheta(t)}{dt}$$

$$e(t) = k_e \omega(t)$$

$$C_{em}(t) = k_t i_r(t)$$

$$J = J_m + J_l$$

$$B = B_m + B_l$$

$$v_r(t) = \begin{cases} +24 & \vartheta < \vartheta_d \\ -24 & \vartheta \geq \vartheta_d \end{cases}$$

R_r : rotor resistance

L_r : rotor inductance

k_e : voltage feedback constant

k_t : torque constant

J_m : motor inertia

J_l : load inertia

B_m : motor friction coefficient

B_l : load friction coefficient

v_r : rotor supply voltage

i_r : rotor wound current

C_{em} : electromagnetic torque

ω : rotational speed

ϑ : shaft angular position

DF Analysis – *Example of application*

The motor transfer functions are the following

$$W_{\omega}(s) = \frac{k_t}{(sL_a + R_a)(sJ + B) + k_t k_e}$$

$$\begin{aligned} W_g(j\omega) &= \frac{k_t}{j\omega \left((j\omega L_a + R_a)(j\omega J + B) + k_t k_e \right)} = \Re(j\omega) + j \Im(j\omega) \\ &= \frac{k_t (R_a J + L_a B)}{\omega^2 (R_a J + L_a B)^2 + (R_a B + k_t k_e - \omega^2 L_a J)^2} \\ &\quad - j \frac{k_t (R_a B + k_t k_e - \omega^2 L_a J)}{\omega \left[\omega^2 (R_a J + L_a B)^2 + (R_a B + k_t k_e - \omega^2 L_a J)^2 \right]} \end{aligned}$$

DF Analysis – *Example of application*

Taking into account the parameters of the motor and of the load

$R=0.4$; % rotor resistance

$L=0.001$; % rotor inductance

$k_e=0.3$; % voltage feedback constant

$k_t=0.3$; % torque constant

$J_m=0.01$; % motor inertia

$J_l=0.09$ % load inertia

$B_m=0.05$; % motor friction coefficient

$B_l=0.05$; %load friction coefficient

$J=J_m+J_l$;

$B=B_m+B_l$;

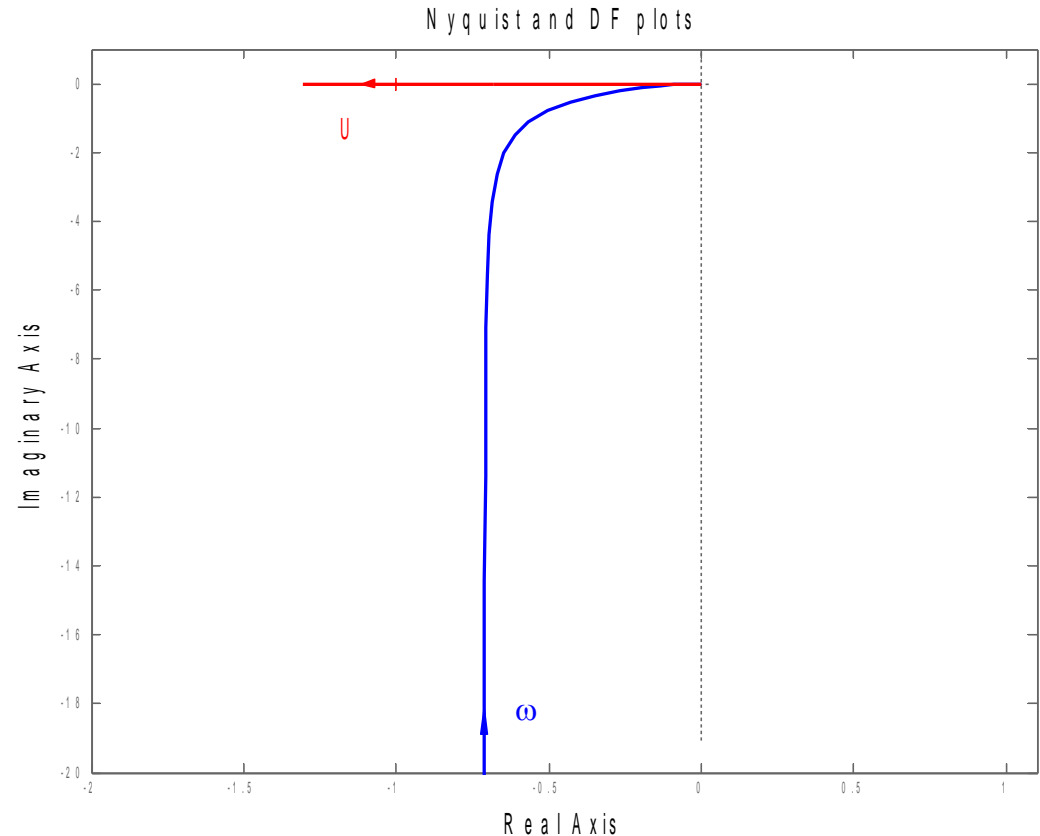

DF Analysis – *Example of application*

Taking into account the parameters of the motor and of the load

$R=0.4$; % rotor resistance

$L=0.001$; % rotor inductance

$k_e=0.3$; % voltage feedback constant

$k_t=0.3$; % torque constant

$J_m=0.01$; % motor inertia

$J_l=0.09$ % load inertia

$B_m=0.05$; % motor friction coefficient

$B_l=0.05$; %load friction coefficient

$J=J_m+J_l$;

$B=B_m+B_l$;

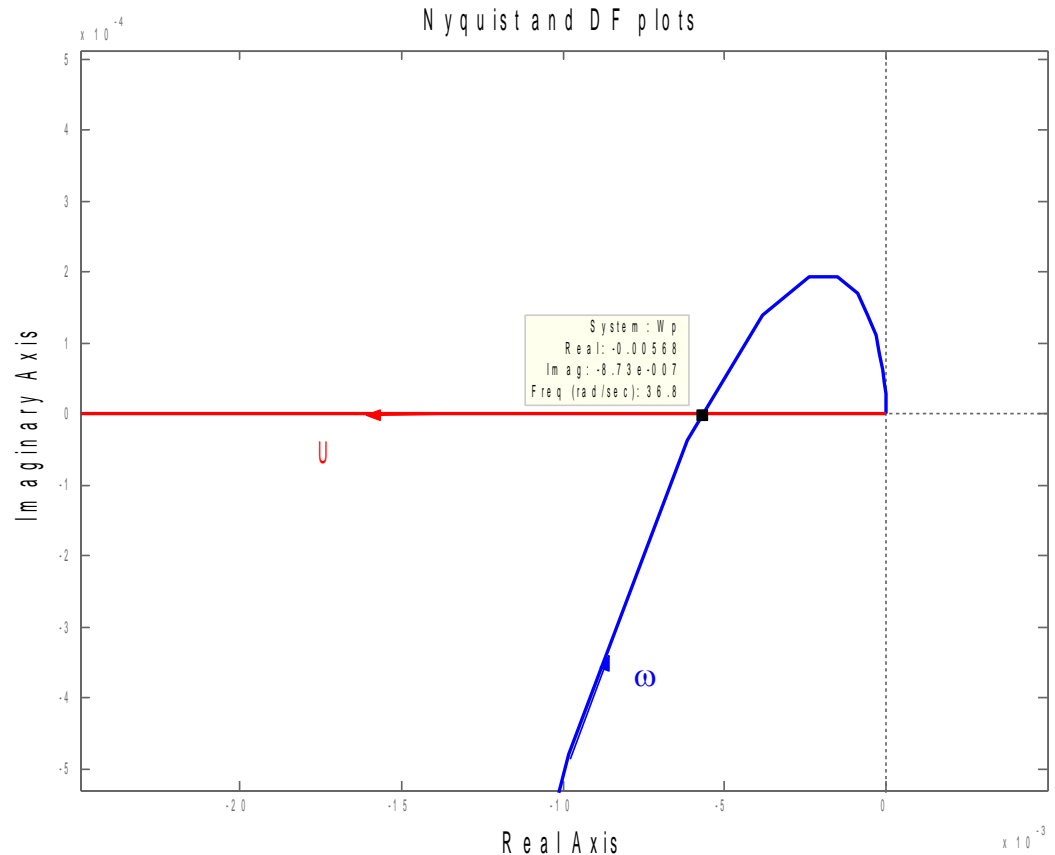

$$\omega \Big|_{\Im(W_p(j\omega))=0} = \omega_{cr} = \sqrt{\frac{R_a B + k_t k_e}{L_a J}} = 36.056 \text{ rad/s}$$

$$\bar{U} = -\frac{4M}{\pi} \cdot \Re(W_p(j\omega_{cr})) = 0.1759 \text{ rad}$$

DF Analysis – *Example of application*

Taking into account the parameters of the motor and of the load

$R=0.4$; % rotor resistance

$L=0.001$; % rotor inductance

$k_e=0.3$; % voltage feedback constant

$k_t=0.3$; % torque constant

$J_m=0.01$; % motor inertia

$J_l=0.09$ % load inertia

$B_m=0.05$; % motor friction coefficient

$B_l=0.05$; %load friction coefficient

$J=J_m+J_l$;

$B=B_m+B_l$;

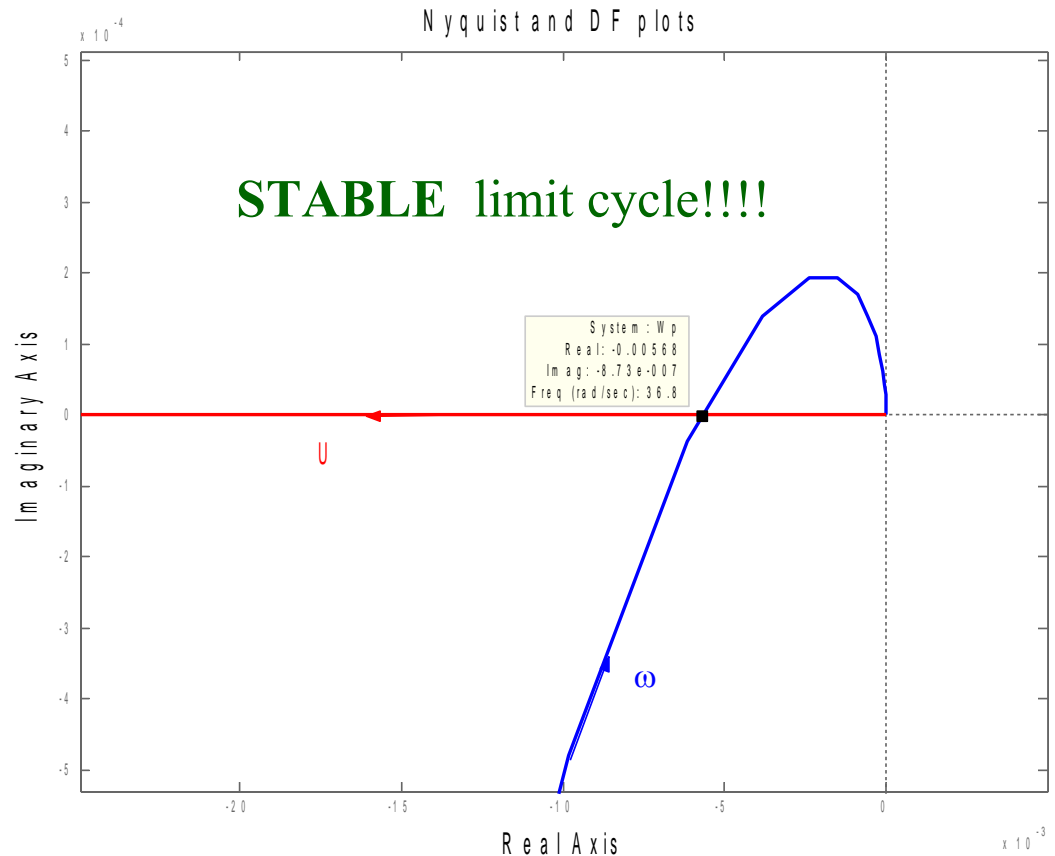

$$\omega \Big|_{\Im(W_p(j\omega))=0} = \omega_{cr} = \sqrt{\frac{R_a B + k_t k_e}{L_a J}} = 36.056 \text{ rad/s}$$

$$\bar{U} = -\frac{4M}{\pi} \cdot \Re(W_p(j\omega_{cr})) = 0.1759 \text{ rad}$$

DF Analysis – *Example of application*

The system presents a periodic steady-state oscillation

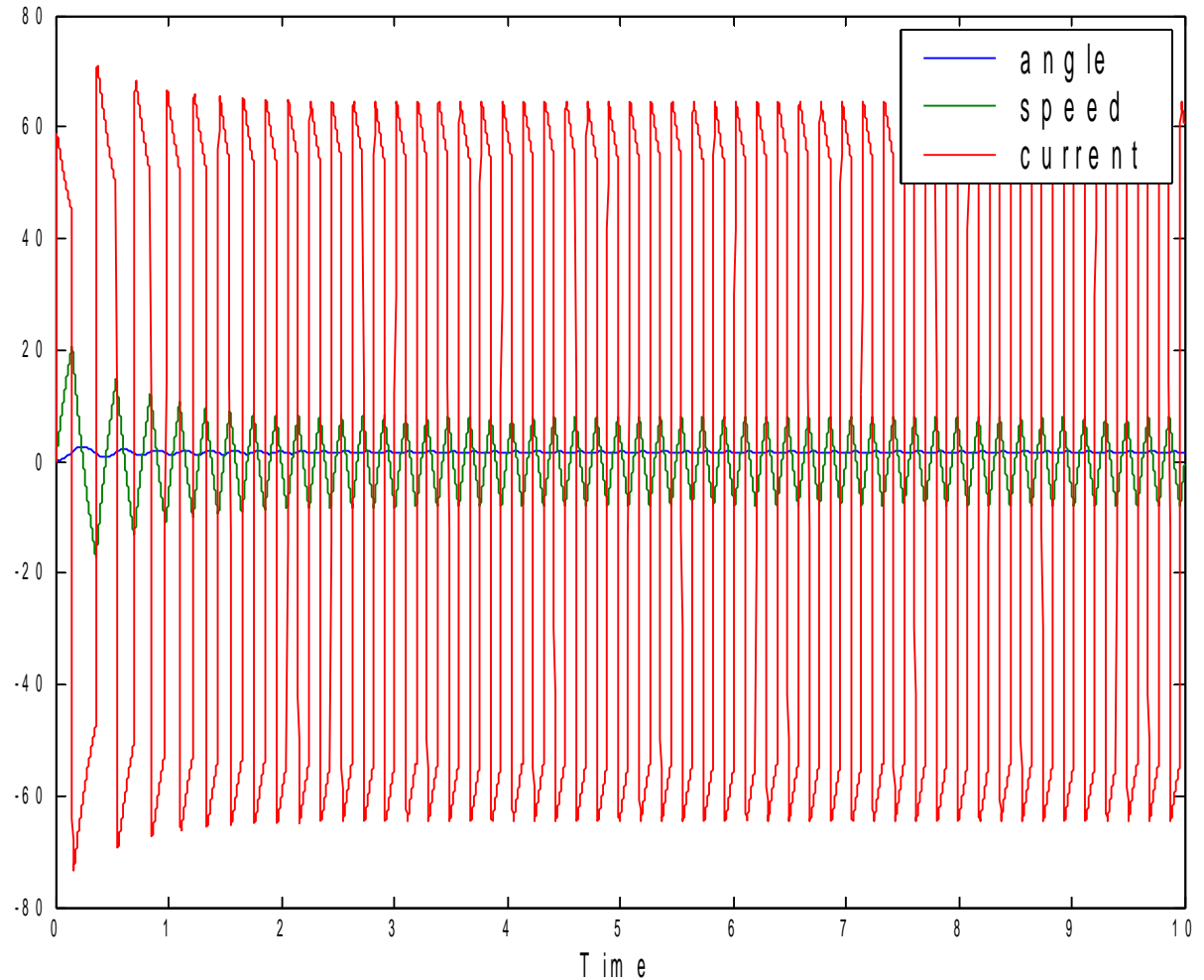

DF Analysis – *Example of application*

The system presents a periodic steady-state oscillation

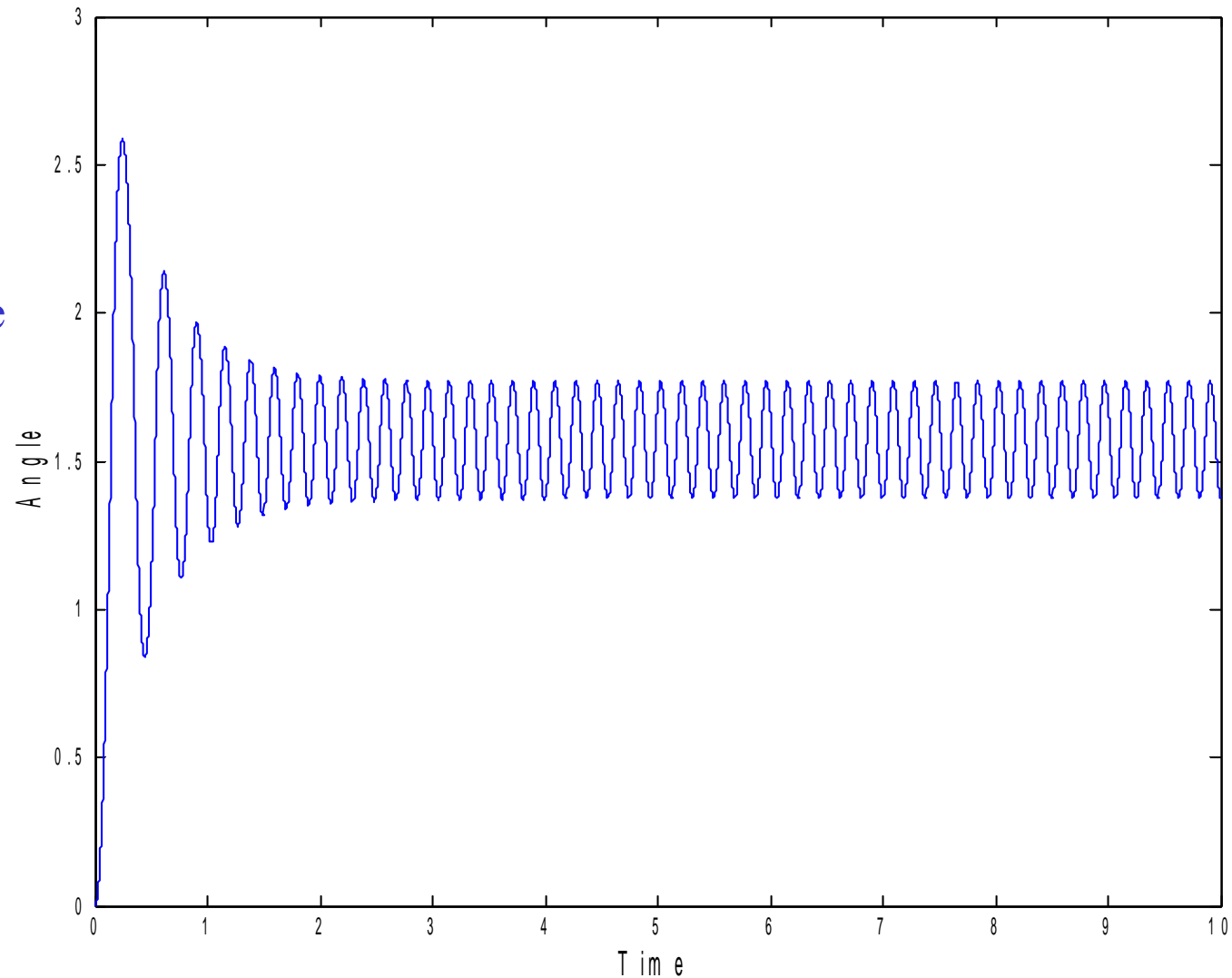

DF Analysis – *Example of application*

The system presents a periodic steady-state oscillation

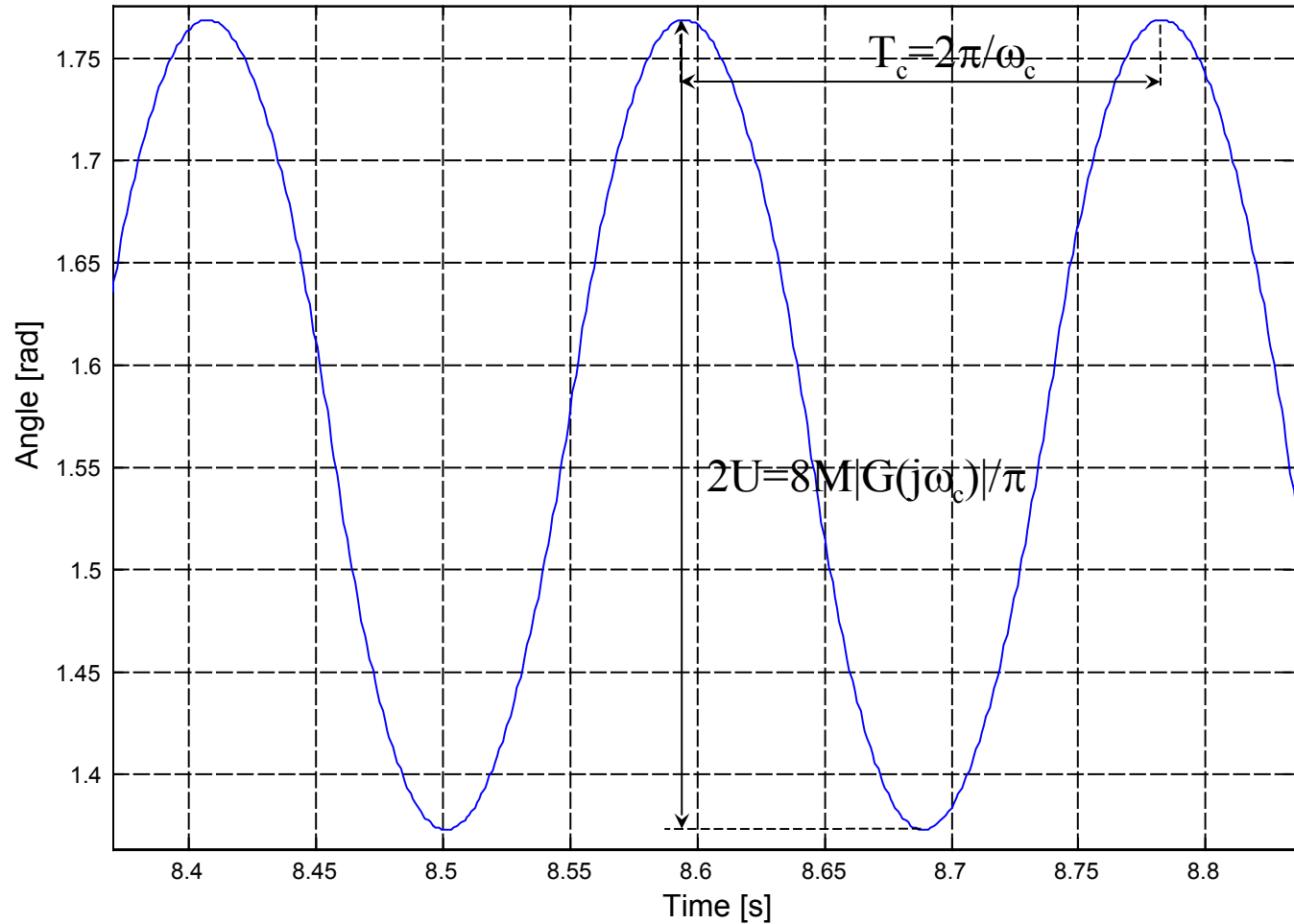

DF Analysis – *Example of application*

What does it happen if the same control law is applied to the speed control problem?

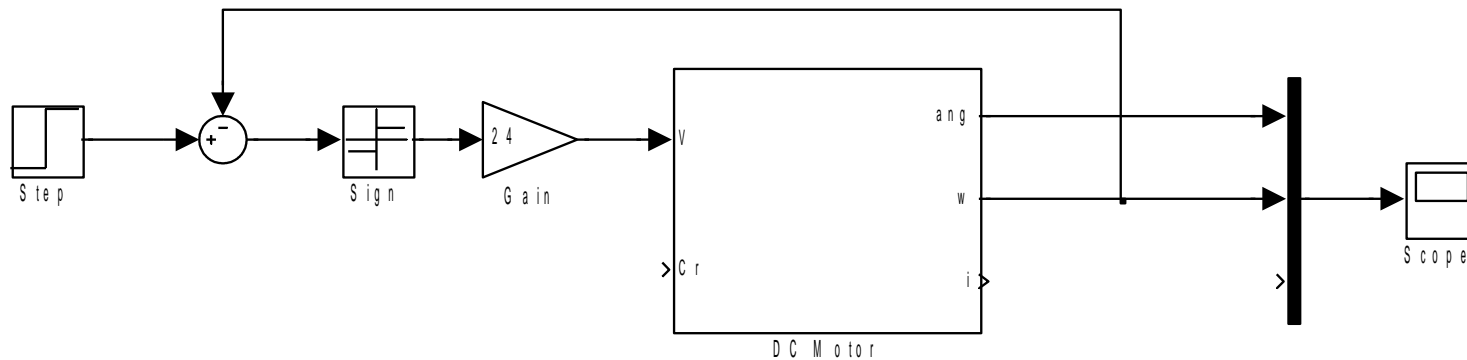

$$W_{\omega}(s) = \frac{k_t}{(sL_a + R_a)(sJ + B) + k_t k_e}$$

The linear plant is characterised by an all-pole transfer function with relative degree two, therefore there is no crossing of the Nyquist plot with the real negative axis, but the origin at $\omega = +\infty$ (corresponding to $U=0$ in the DF plot)

DF Analysis – *Example of application*

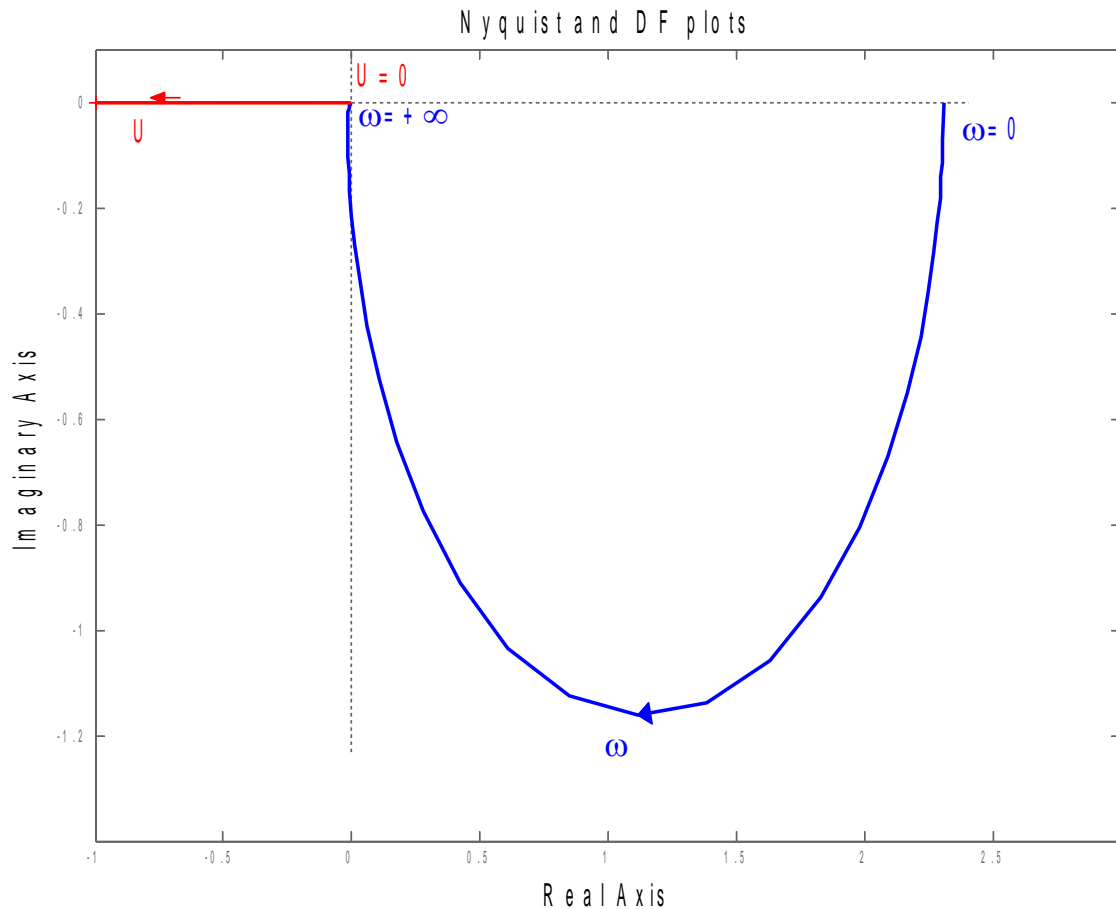

The Nyquist plot of the linear system is tangent to the negative reciprocal of the DF at the origin, i.e., $U=0$ and $\omega=+\infty$

A sliding mode behaviour is established asymptotically

DF Analysis – *Example of application*

Possibly a sort of
dead-bit control,
or finite time
stabilisation
seems to appear

Can it be a
sliding mode
behaviour?

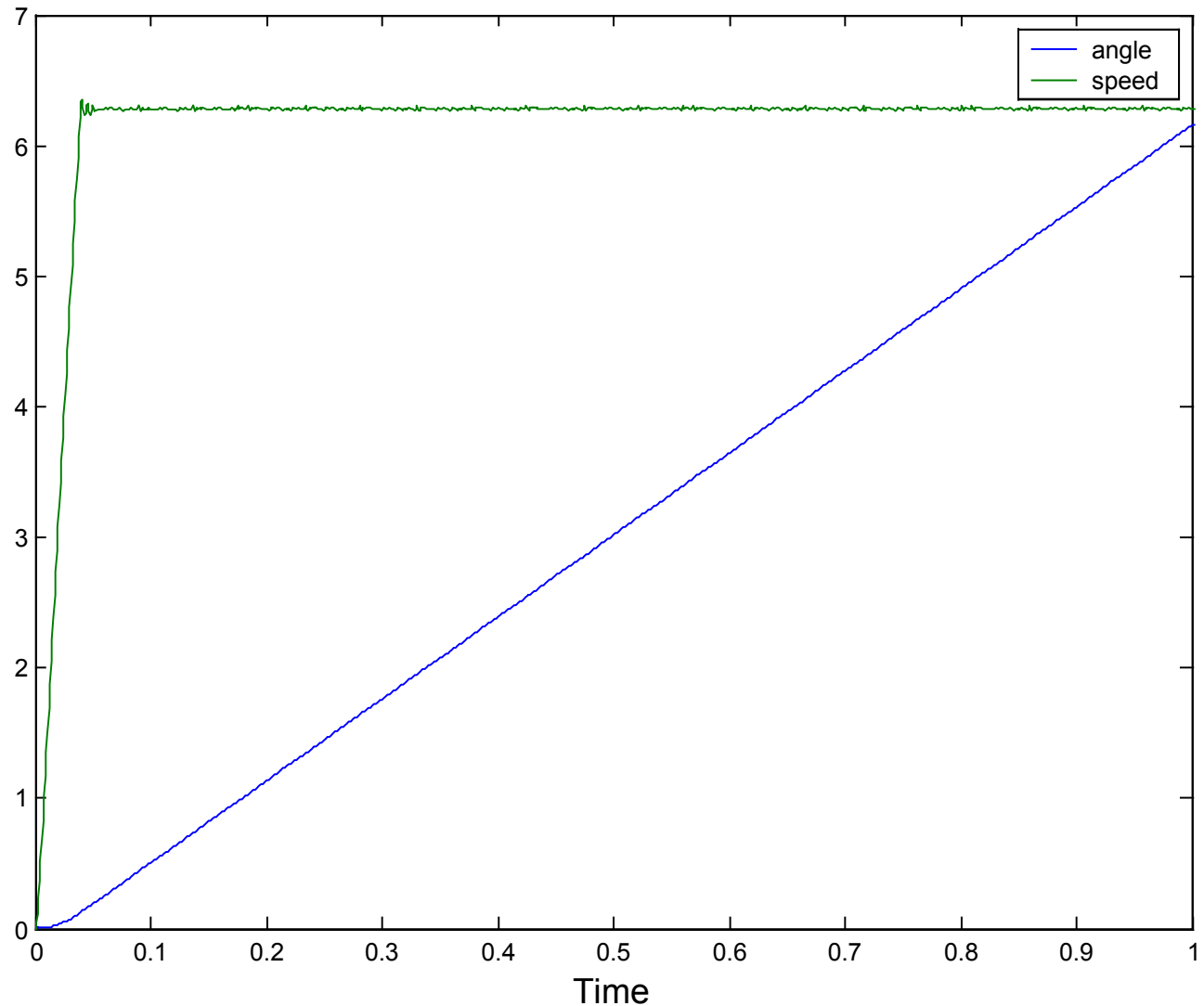

DF Analysis – *Example of application*

By reducing the integration step of the simulation it is apparent that the stabilisation is asymptotic

Can it be a sliding mode behaviour?

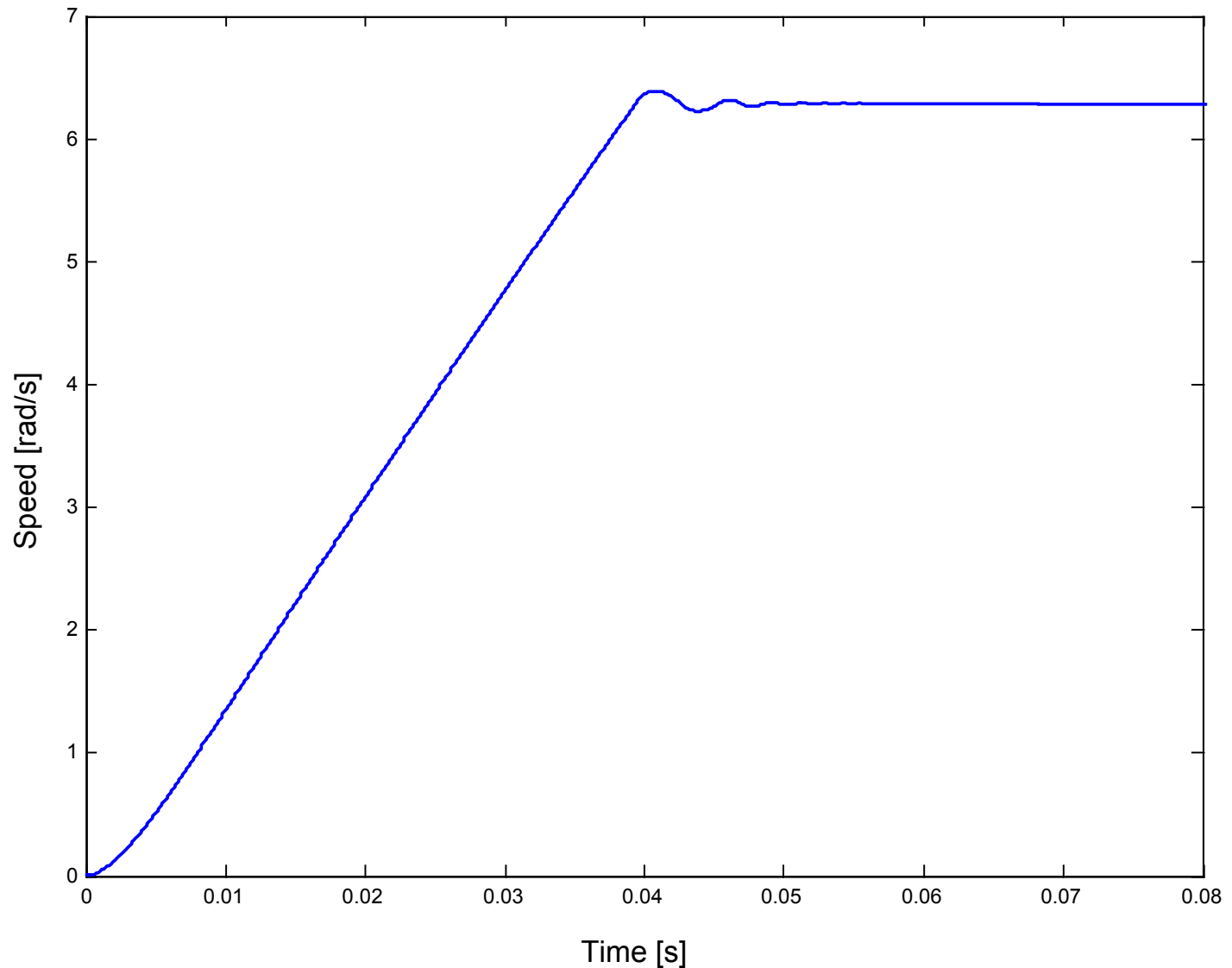

DF Analysis – *Example of application*

By reducing the integration step of the simulation it is apparent that the stabilisation is asymptotic

The rotor current tends to a constant value, i.e. an asymptotic (*2nd order*) sliding mode appears

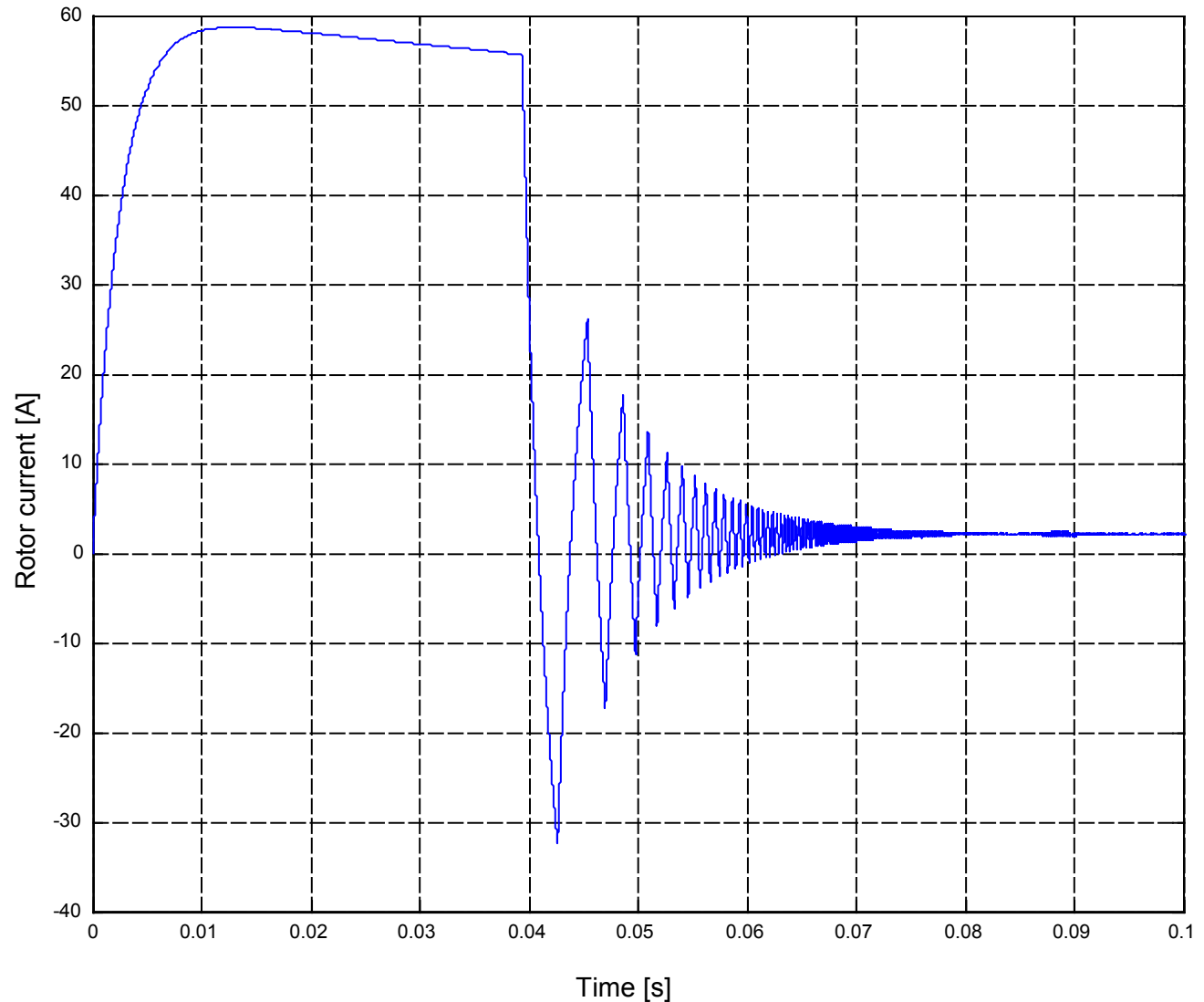

DF Analysis – *Example of application*

The DC motor is a second order system whose state variables are the rotor speed and current

$$\begin{aligned}\frac{d\omega(t)}{dt} &= \frac{B}{J}\omega(t) + \frac{k_t}{J}i_r(t) \\ \frac{di_r(t)}{dt} &= -\frac{k_e}{L_r}\omega(t) - \frac{R_r}{L_r}i_r(t) + \frac{1}{L_r}v_r(t) \\ y(t) &= \frac{B}{J}\omega(t) + \frac{k_t}{J}i_r(t) + 2\omega(t)\end{aligned}$$

The system transfer function has a zero in -2 , and if the system output is steered to zero in a finite time, than the system behaves as a first order system with time constant $\tau=0.5$

DF Analysis – *Example of application*

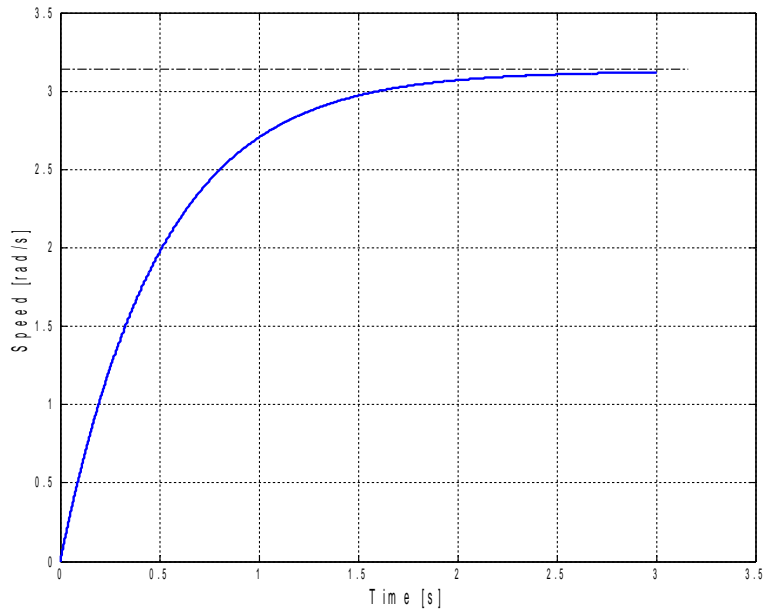

It is apparent that the shaft speed tends to the steady state value π as a first order system with $\tau=0.5$

Apart from a very short transient, the state trajectory tends to the steady-state values sliding on a linear manifold of the state space

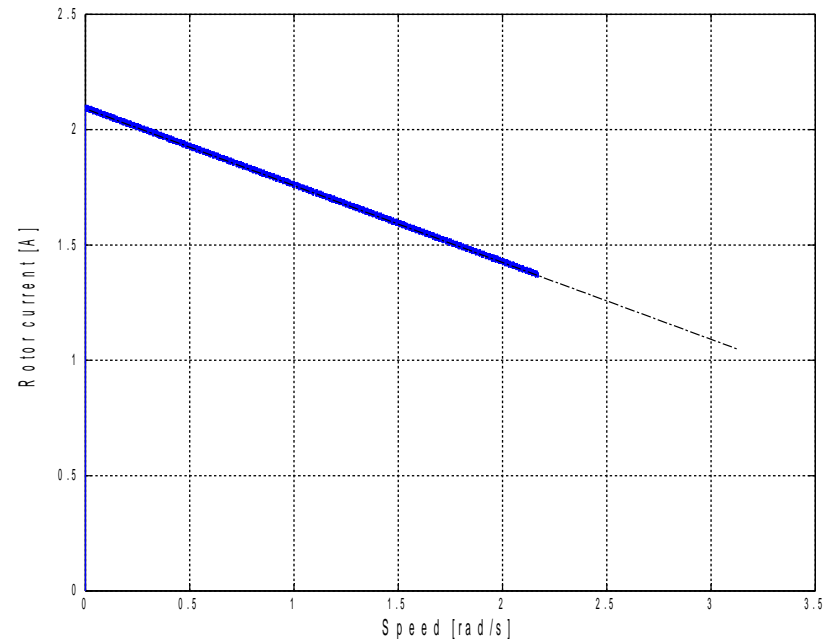

DF Analysis – *Example of application*

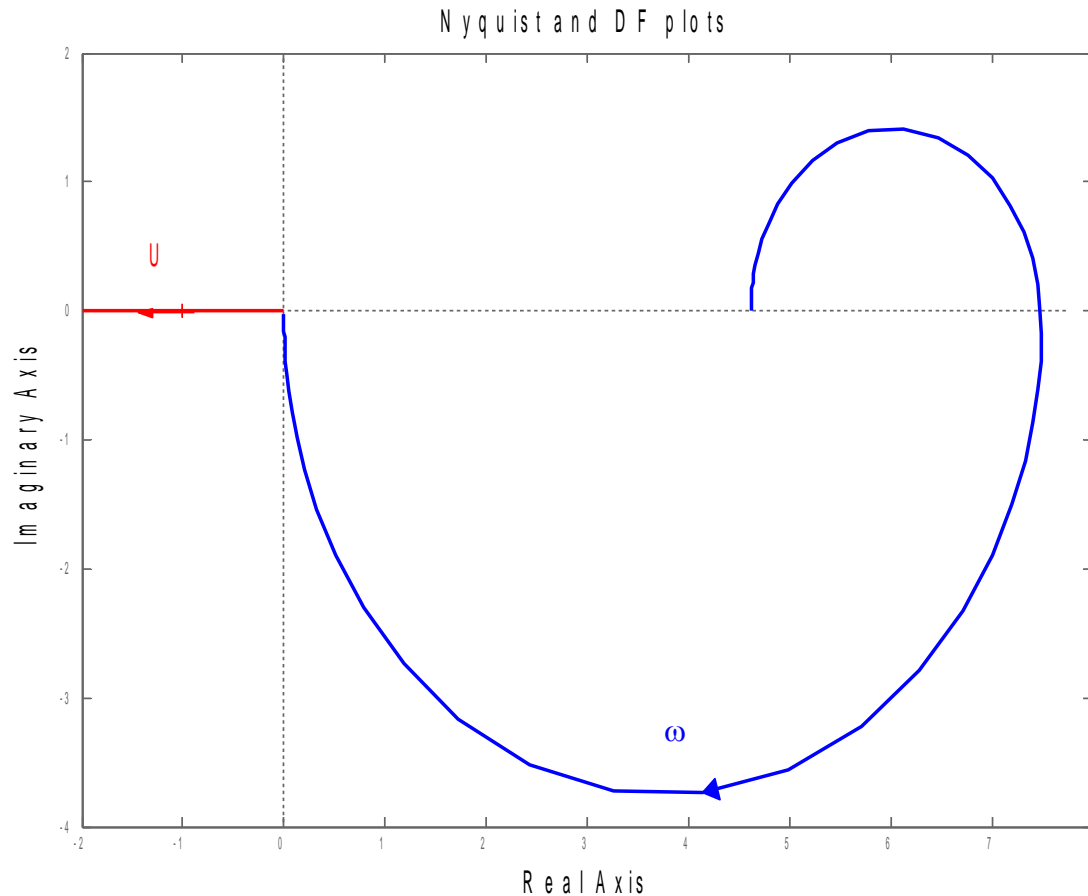

The Nyquist plot of the linear system crosses the negative reciprocal of the DF at the origin, i.e., $U=0$ and $\omega=+\infty$

A sliding mode behaviour is established in a finite time