



Esercitazione: Il multimetro

NI My DAQ



Simpson 260 www.econ.net

Fluke 177





Esercitazione Pratica

- Datasheet (accuratezza, range di funzionamento, etc.)
- Prove con vari tipi di segnali
- Comportamento alle basse e alte frequenze
- Misure di resistenza a due morsetti e quattro morsetti

Esercitazione Pratica

Caratteristiche principali

- Misurazione di correnti e tensioni True-rms
- **Precisione di base 0,09% (177, 179)**
- Risoluzione 6000 punti
- Display digitale con istogramma analogico e retroilluminazione (serie 177,179)
- Selezione della gamma manuale e automatica
- Funzioni di display Hold e Auto Hold
- Misurazioni di frequenza e capacità
- Misurazioni di resistenza, continuità e diodi
- Misurazioni di temperatura (serie 179)
- Registrazione Min-Max-Media
- La modalità di attenuazione consente il filtraggio dei valori in ingresso che cambiano rapidamente
- Sostituzione agevole delle batterie senza la necessità di aprire la custodia
- Calibrazione "a scatola chiusa" dal pannello frontale
- Custodia ergonomica con guscio protettivo integrato
- EN61010-1 CAT III 1000V / CAT IV 600V
- Velocità di misurazione doppia rispetto ad altri multimetri



Fluke 177





Specifiche Fluke 177



Specifiche elettriche

Funzione	Gamma ^[1]	Risoluzione	Precisione \pm [% della lettura] + [punti]		
			175	177	179
Volt c.a. ^{[2][3]}	600,0 mV	0,1 mV	1,0 % + 3 (da 45 Hz a 500 Hz)	1,0 % + 3 (da 45 Hz a 500 Hz)	1,0 % + 3 (da 45 Hz a 500 Hz)
	6,000 V 60,00 V 600,0 V 1000 V	0,001 V 0,01 V 0,1 V 1 V	2,0 % + 3 (da 500 Hz a 1 kHz)	2,0 % + 3 (da 500 Hz a 1 kHz)	2,0 % + 3 (da 500 Hz a 1 kHz)
Misure di tensione in mV	600,0 mV	0,1 mV	0,15 % + 2	0,09 % + 2	0,09 % + 2
Misure di tensione (V) in c.c.	6,000 V 60,00 V 600,0 V	0,001 V 0,01 V 0,1 V	0,15 % + 2	0,09 % + 2	0,09 % + 2
	1000 V	1 V	0,15 % + 2	0,15 % + 2	0,15 % + 2
Prova di continuità	600 Ω	1 Ω	Il Prodotto emette un segnale acustico a <25 Ω , il cicalino si spegne a >250 Ω ; rileva interruzioni o cortocircuiti di entità pari o superiore a 250 μ s.		
Resistenza	600,0 Ω	0,1 Ω	0,9 % + 2	0,9 % + 2	0,9 % + 2
	6,000 k Ω	0,001 k Ω	0,9 % + 1	0,9 % + 1	0,9 % + 1
	60,00 k Ω	0,01 k Ω	0,9 % + 1	0,9 % + 1	0,9 % + 1
	600,0 k Ω	0,1 k Ω	0,9 % + 1	0,9 % + 1	0,9 % + 1
	6,000 M Ω	0,001 M Ω	0,9 % + 1	0,9 % + 1	0,9 % + 1
	50,00 M Ω	0,01 M Ω	1,5 % + 3	1,5 % + 3	1,5 % + 3



Using NI myDAQ with the NI ELVISmx Digital Multimeter Soft Front Panel

NI My DAQ

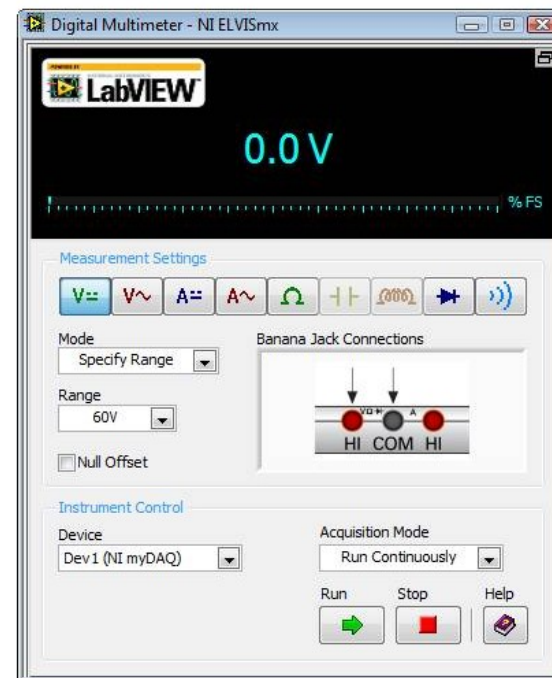

<http://www.ni.com/tutorial/11501/en/>



MyDAQ

Figure 2. NI myDAQ Hardware Block Diagram

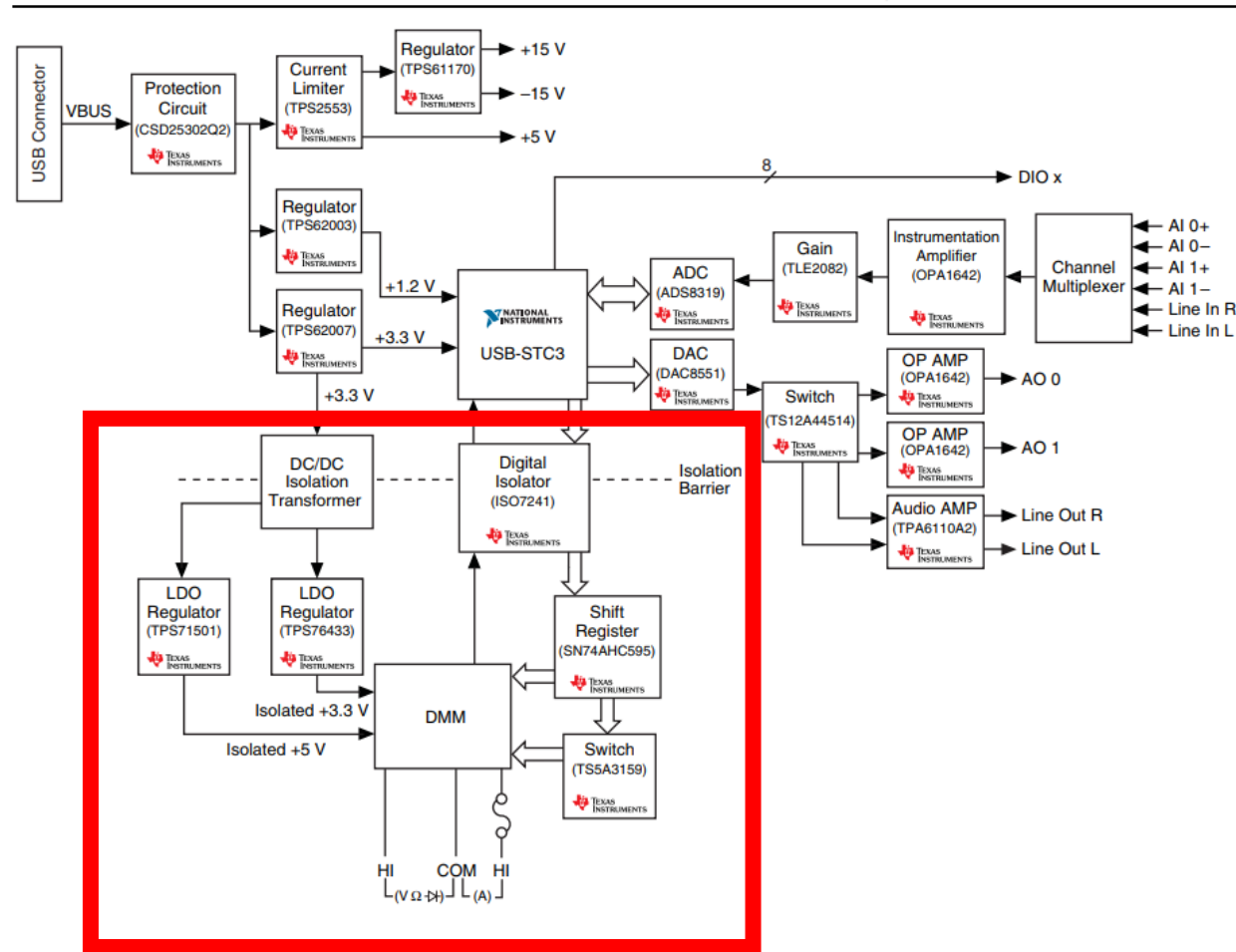



Specifiche MyDAQ

Digital Multimeter

- Functions¹ DC voltage, AC voltage, DC current, AC current, resistance, diode, continuity
- Isolation level 60 VDC/20 V_{rms}, Measurement Category I
-  **Caution** Do *not* use this device for connection to signals or for measurements within Measurement Categories II, III, or IV. For more information on Measurement Categories, refer to the *Safety Voltages* section.
- Connectivity Banana jacks
- Resolution 3.5 digits
- Input coupling DC (DC Voltage, DC Current, Resistance, Diode, Continuity); AC (AC Voltage, AC Current)

Voltage Measurement

- DC ranges 200 mV, 2 V, 20 V, 60 V
- AC ranges 200 mV_{rms}, 2 V_{rms}, 20 V_{rms}



Note All AC voltage accuracy specifications apply to signal amplitudes greater than 5% of range.

Accuracy

Function	Range	Resolution	Accuracy	
			± ([% of Reading] + Offset)	
DC Volts	200.0 mV	0.1 mV	0.5% + 0.2 mV	
	2.000 V	0.001 V	0.5% + 2 mV	
	20.00 V	0.01 V	0.5% + 20 mV	
	60.0 V	0.1 V	0.5% + 200 mV	
			40 to 400 Hz	400 to 2,000 Hz
AC Volts	200.0 mV	0.1 mV	1.4% + 0.6 mV*	—
	2.000 V	0.001 V	1.4% + 0.005 V	5.4% + 0.005 V
	20.00 V	0.01 V	1.5% + 0.05 V	5.5% + 0.05 V

* The accuracy for AC Volts 200.0 mV range is in the frequency range of 40 Hz to 100 Hz. For example, for a 10 V using the DC Volts function in the 20.00 V range, calculate the accuracy using the following equation:

$$10 \text{ V} \times 0.5\% + 20 \text{ mV} = 0.07 \text{ V}$$

Input impedance 10 MΩ



Specifiche MyDAQ

Resistance Measurement

Ranges 200 Ω , 2 k Ω , 20 k Ω , 200 k Ω , 2 M Ω , 20 M Ω

Accuracy

Function	Range	Resolution	Accuracy
			\pm ([% of Reading] + Offset)
Ω	200.0 Ω	0.1 Ω	0.8% + 0.3 Ω *
	2.000 k Ω	0.001 k Ω	0.8% + 3 Ω
	20.00 k Ω	0.01 k Ω	0.8% + 30 Ω
	200.0 k Ω	0.1 k Ω	0.8% + 300 Ω
	2.000 M Ω	0.001 M Ω	0.8% + 3 k Ω
	20.00 M Ω	0.01 M Ω	1.5% + 50 k Ω

* Exclusive of lead wire resistance

Cavi di collegamento



Cocodrillo – Banana
30 V, 15 A



Cocodrillo – BNC

Cavi di collegamento

BNC (Bayonet Neill–Concelman)
< 4 GHz, < 500 V



Screw Terminal



Puntali



Schema circuitale: Misure di Tensione

- Collegamenti

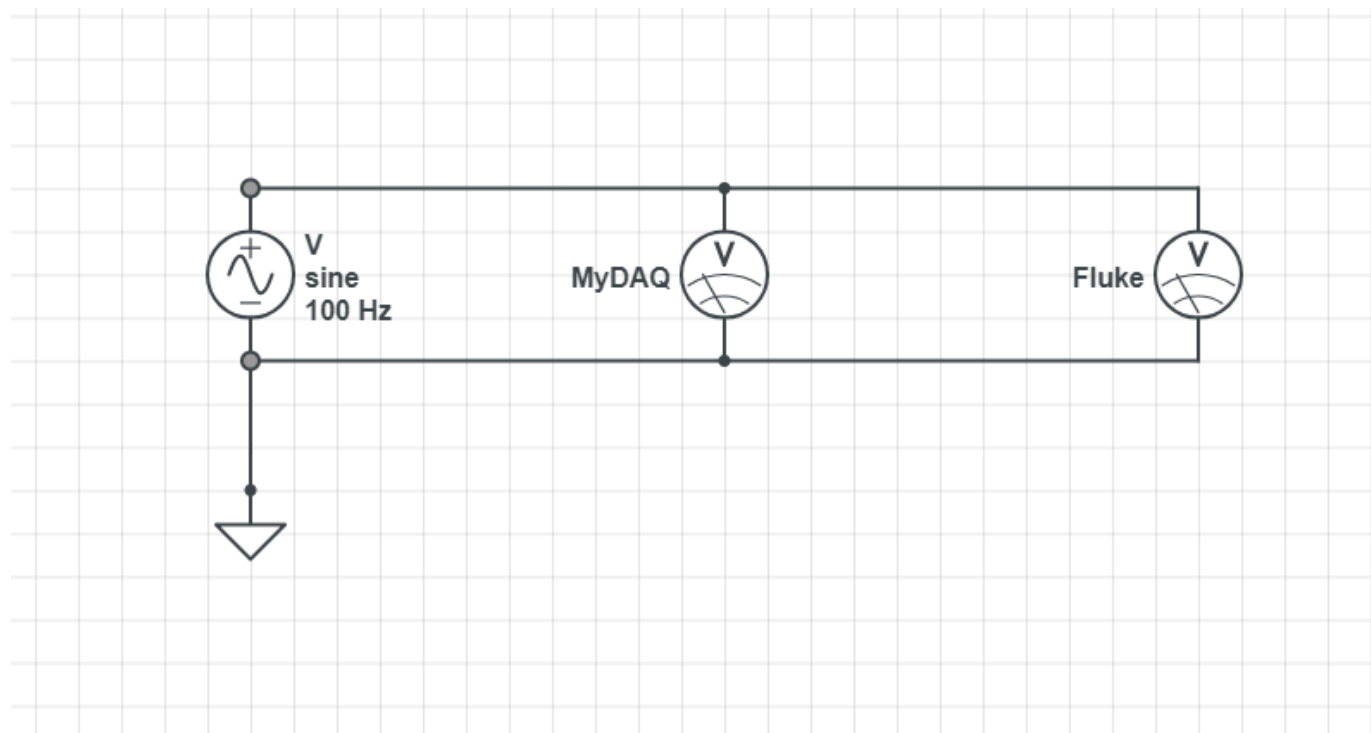

Using myDAQ with the NI ELVISmx Function Generator Soft Front Panel

NI My DAQ

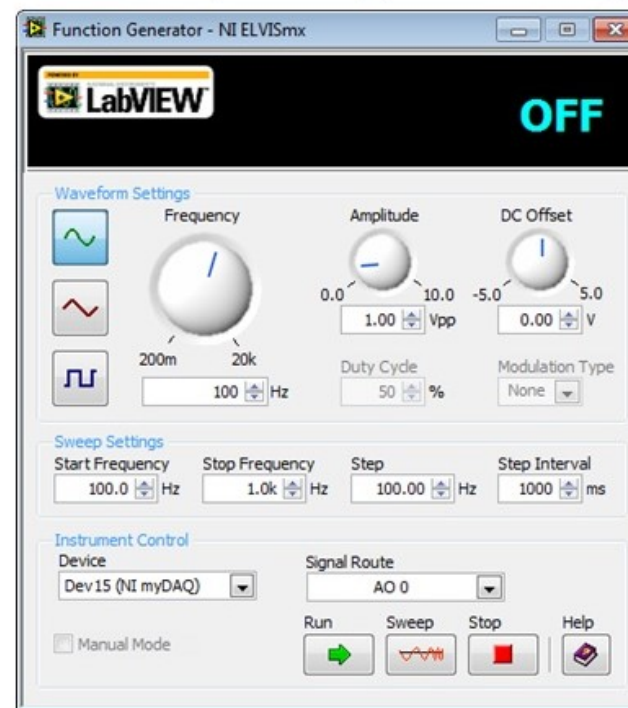

<http://www.ni.com/tutorial/11503/en/>

<http://www.ni.com/tutorial/11420/en/>



Schema circuitale: Misure di Tensione

- Collegamenti

Analog Output

Number of channels..... 2 ground-referenced or 1 stereo audio output

DAC resolution..... 16 bits

Maximum update rate..... 200 kS/s

Range

 Analog output ±10 V, ±2 V, DC-coupled

 Audio output ±2 V, AC-coupled

Maximum output current
(analog output)¹ 2 mA

Output impedance

 Analog output 1 Ω

 Audio output 120 Ω

Minimum load impedance
(audio output) 8 Ω



Connector type

Analog output Screw terminals

Audio output 3.5 mm stereo jack



AC-coupling high-pass frequency

(audio output with 32 Ω load)..... 48 Hz

Absolute accuracy

Nominal Range		Typical at 23 °C (mV)	Maximum (18 to 28 °C) (mV)
Positive Full Scale	Negative Full Scale		
10	-10	19.6	42.8
2	-2	5.4	8.8



Slew rate 4 V/μs

Timing accuracy..... 100 ppm of sample rate

Timing resolution..... 10 ns

Overdrive protection ±16 V to AGND

Maximum power-on voltage¹ ±110 mV

Output FIFO size 8,191 samples, shared among channels used

¹ The total power available for the power supplies, analog outputs, and digital outputs is limited to 500 mW (typical)/100 mW (minimum). Refer to the [Calculating Power Consumption](#) section for information on calculating the total power consumption of the components of your system.

Schema circuitale: Misure di Tensione

- Collegamenti (generatore di segnali)

NI myDAQ

I/O Connectors

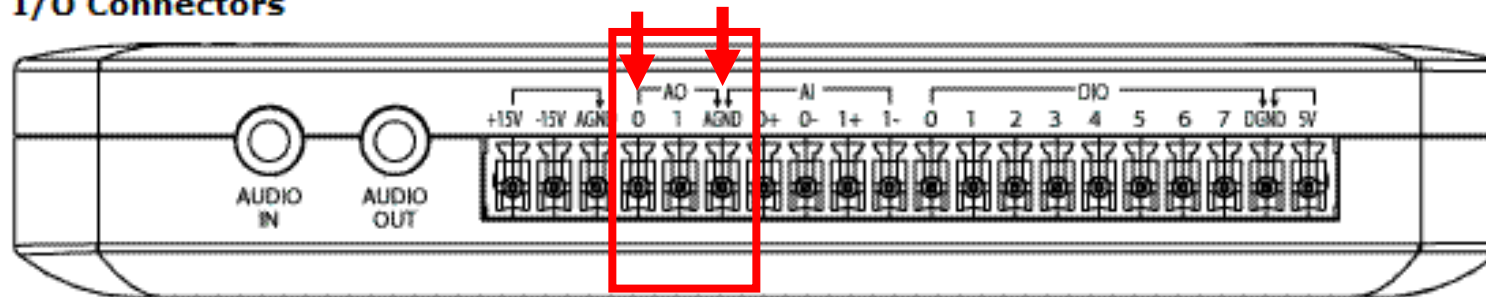

Note DIO pins can also be used as PFI pins.

Schema circuitale: Misure di Tensione

- Collegamenti

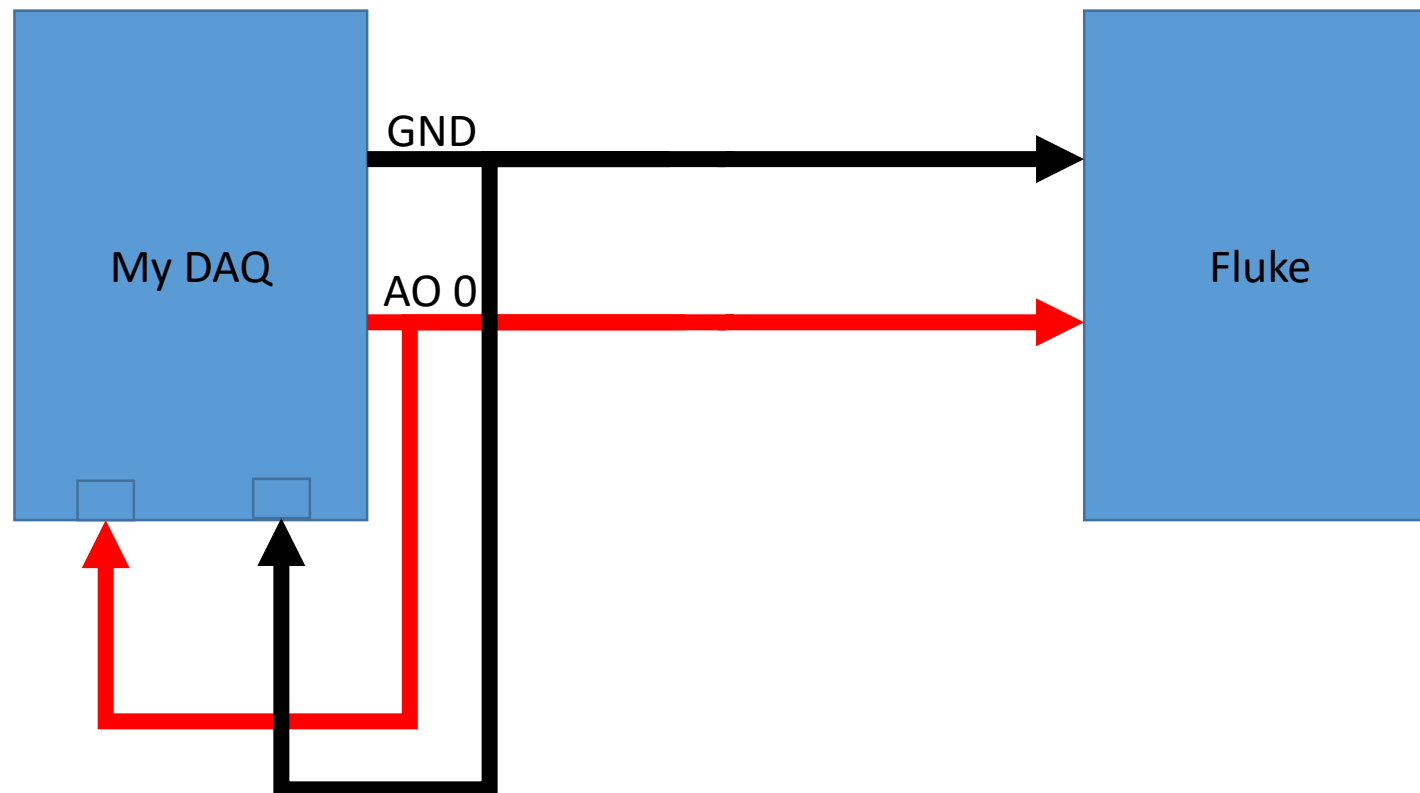

Misure di Resistenza

una resistenza da 27 kΩ con tolleranza del 10%.

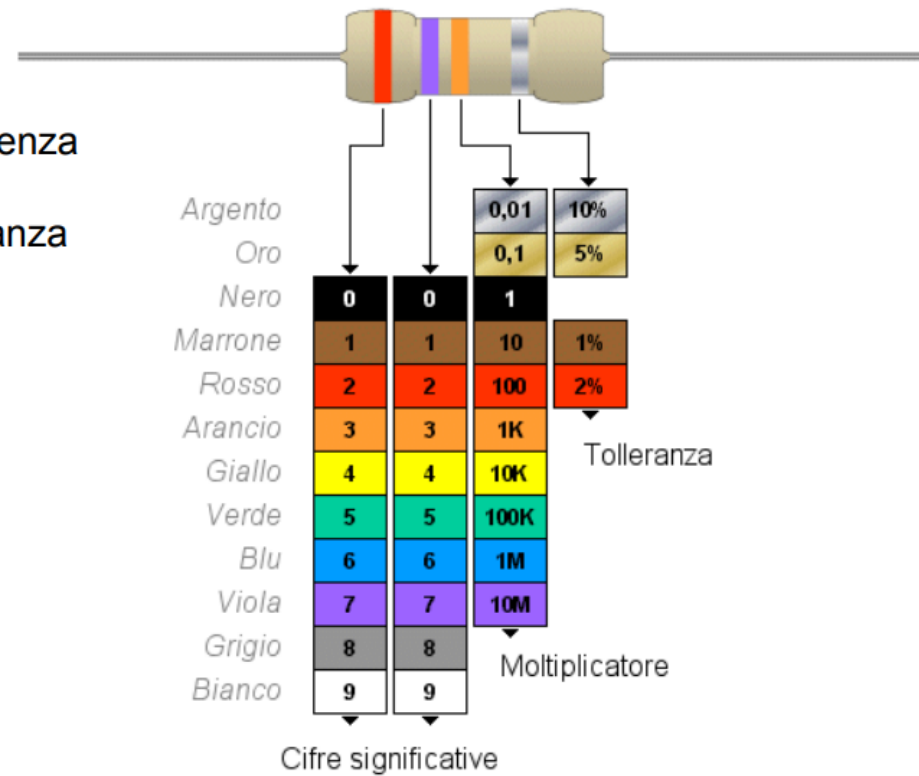

Schema circuitale: Misure di Resistenza 2 morsetti

- Collegamenti

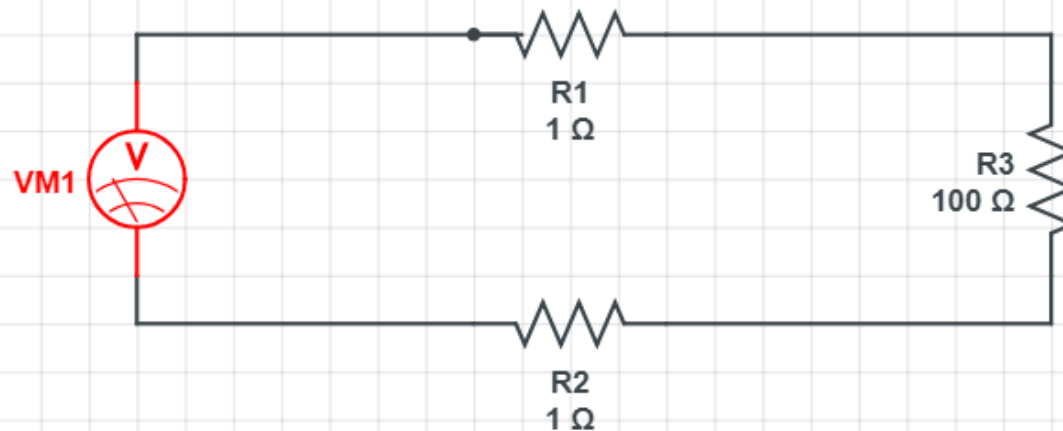

Schema circuitale: Misure di Resistenza 2 morsetti

- Compensazione

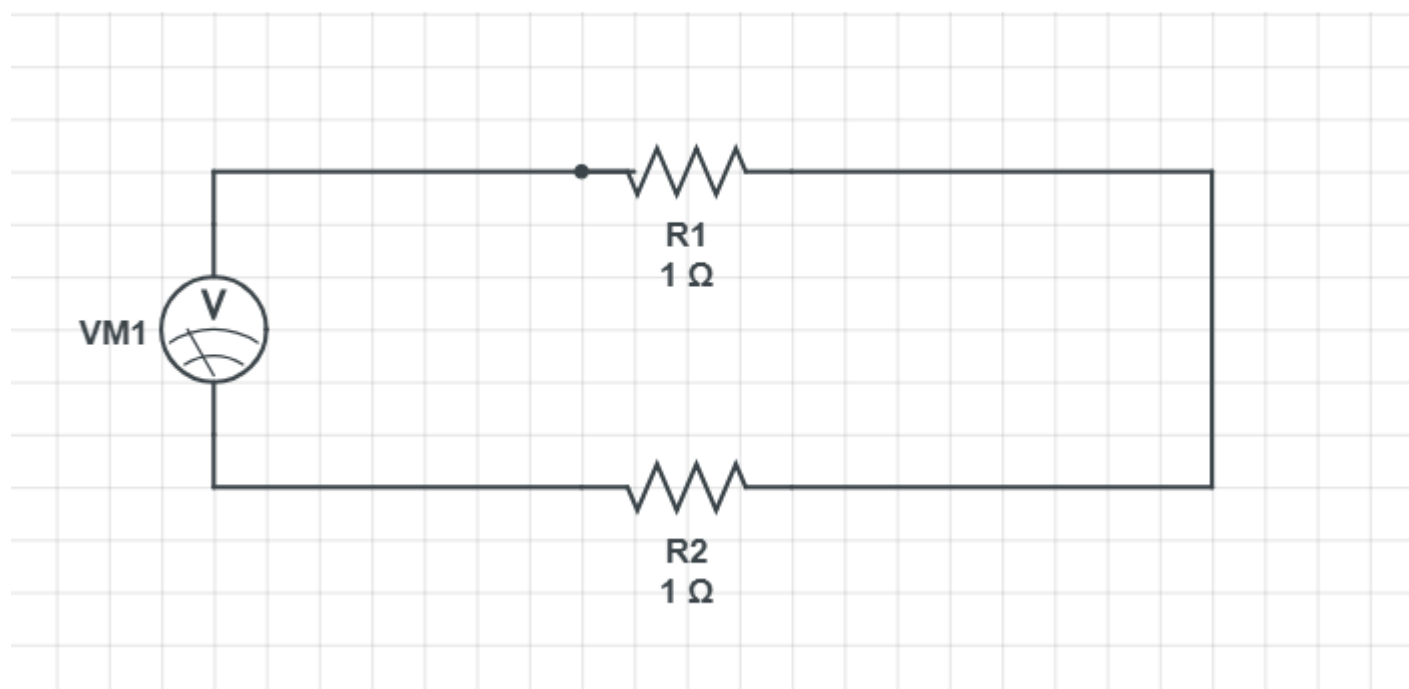

Schema circuitale: Misure di Resistenza 4 morsetti

- Collegamenti

