



Archeologia cristiana e medievale

aa 2020-2021

Modulo A

Lezione IX

Fonti topografiche e pellegrinaggi ai santuari romani

Prof.ssa Rossana Martorelli



FRUIZIONE E UTILIZZO DEI MATERIALI DIDATTICI

- ➔ **E' vietata** la copia, la rielaborazione, la riproduzione dei contenuti e immagini presenti nelle lezioni in qualsiasi forma
- ➔ **E' inoltre vietata** la diffusione, la redistribuzione e la pubblicazione dei contenuti e immagini, incluse le registrazioni delle videolezioni con qualsiasi modalità e mezzo non autorizzati espressamente dall'autore o da Unica

comunicazioni

- Venerdì 6 novembre: NO lezione
- Mercoledì 4 novembre: recupero
lezione ore 12-13.30

itinerari romani

Notitia ecclesiarum

=

De locis sanctis

Itinerario di Beda

Itinerario di Einsiedlen

Itinerario Malmesburiense

Notitia ecclesiarum Urbis Romae



*De locis sanctis martyrum
quae sunt foris civitatis Romae*

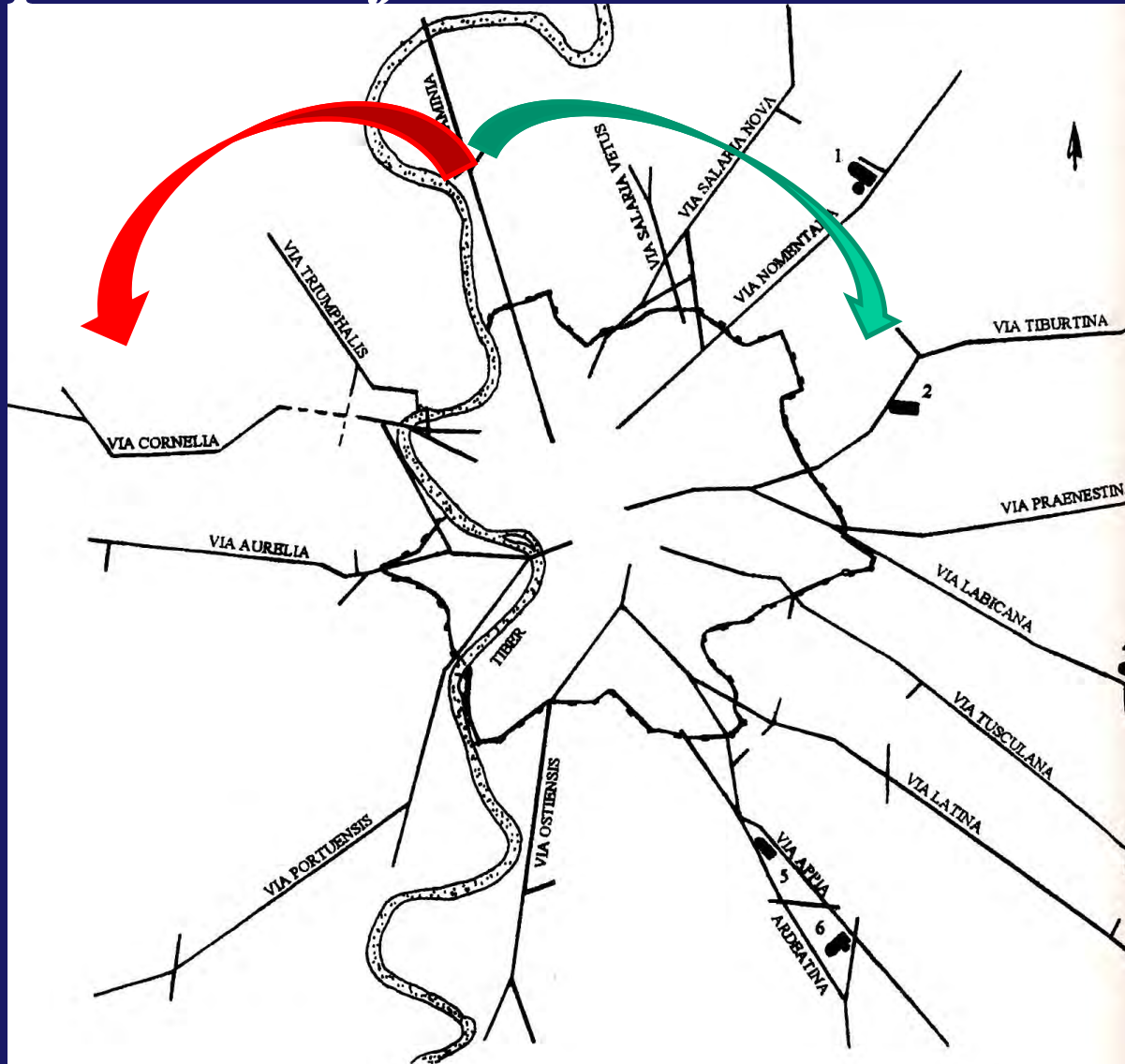

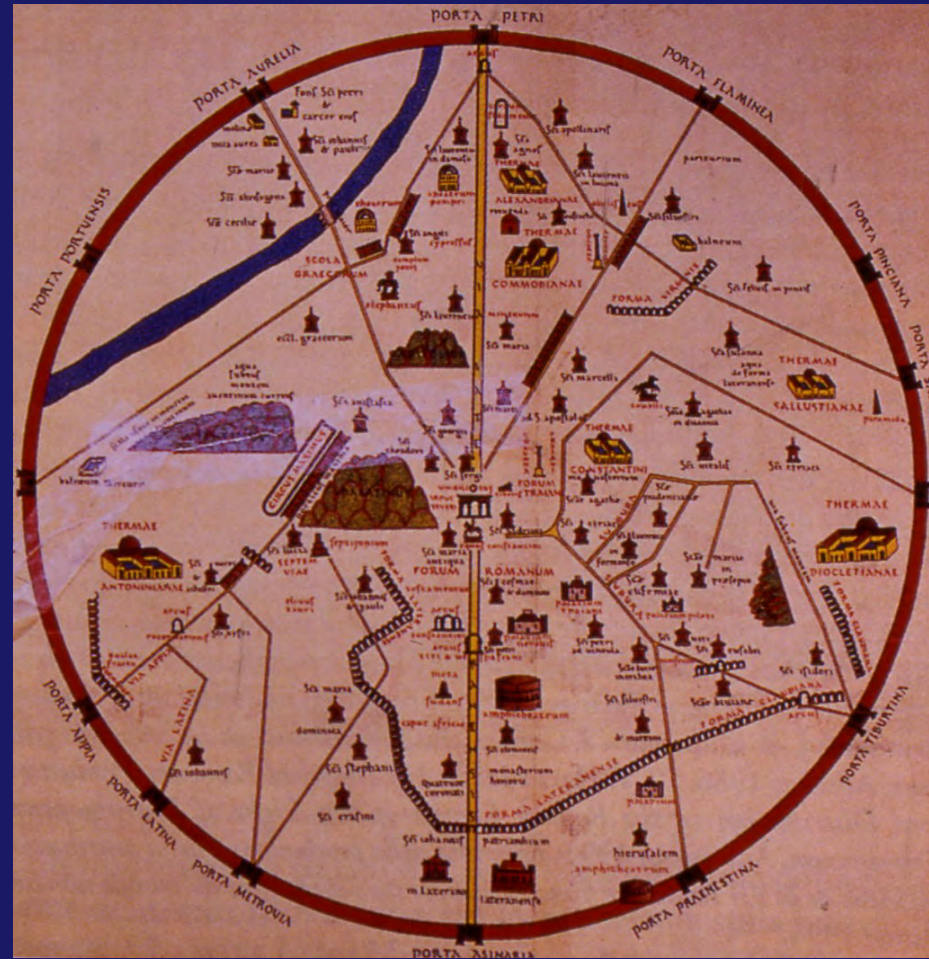

Itinerario di Einsiedlen

De locis

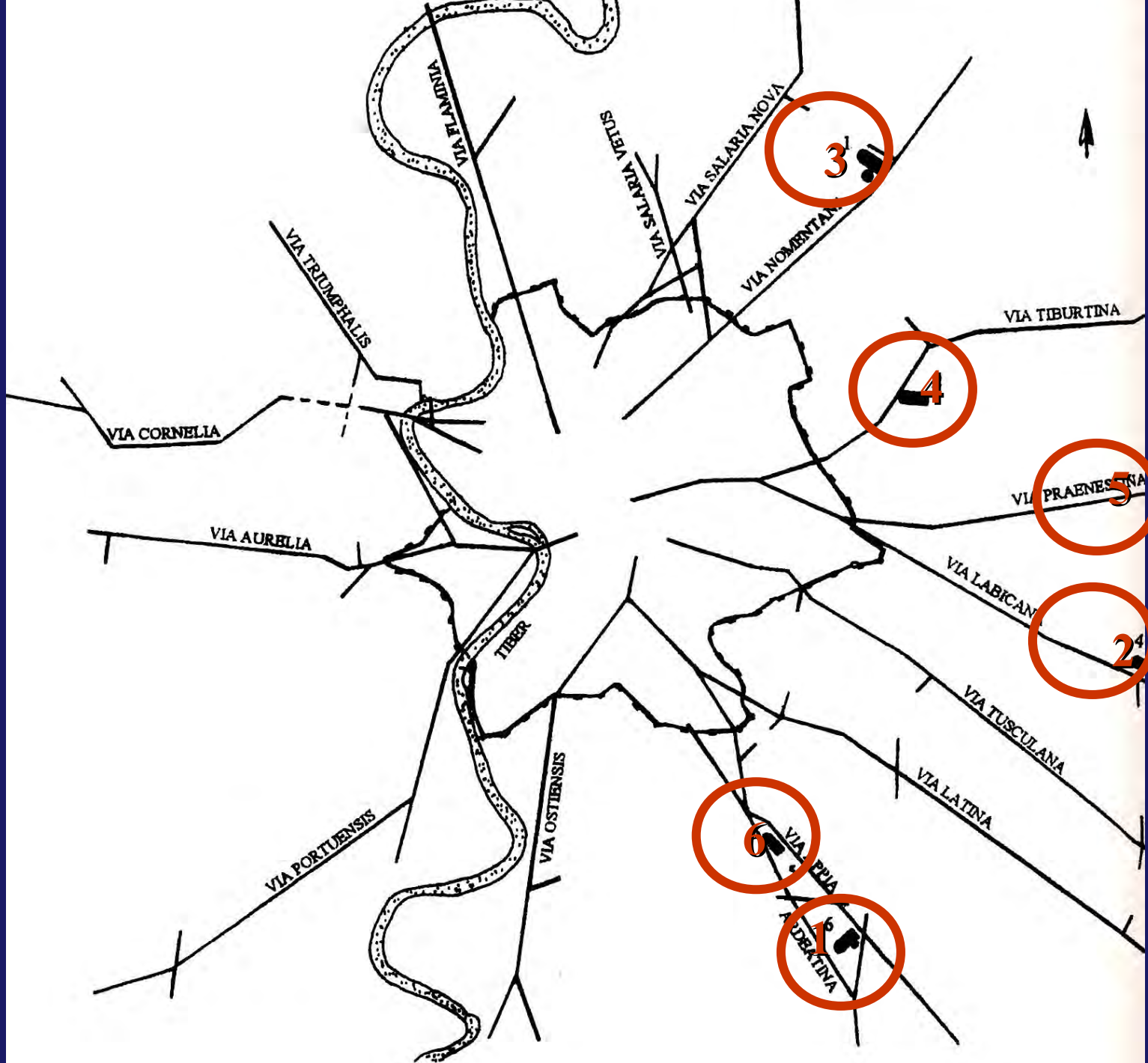

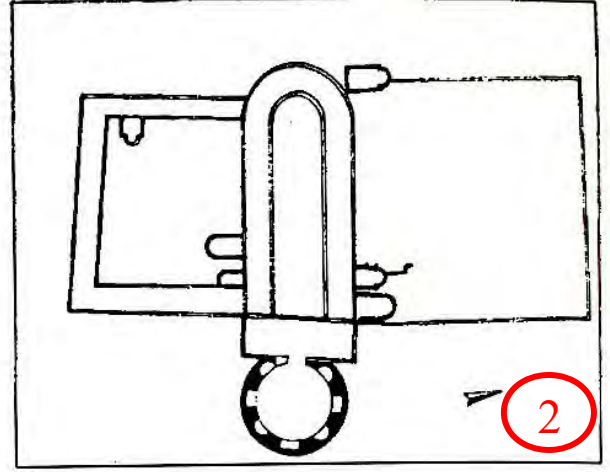
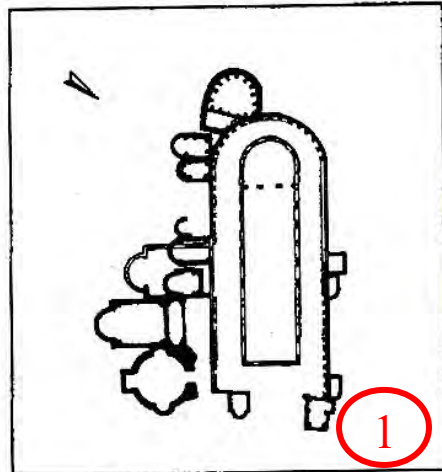
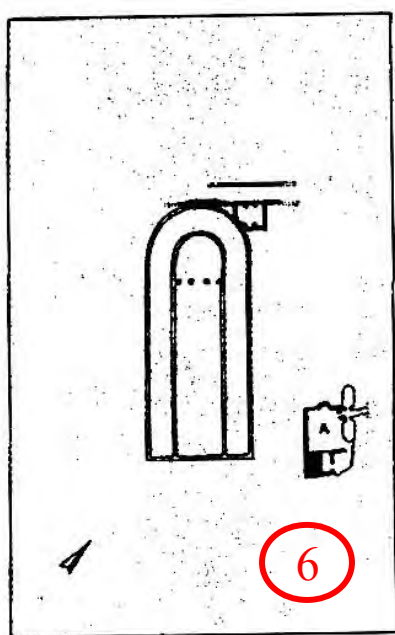

0 10 20 30 40 50m

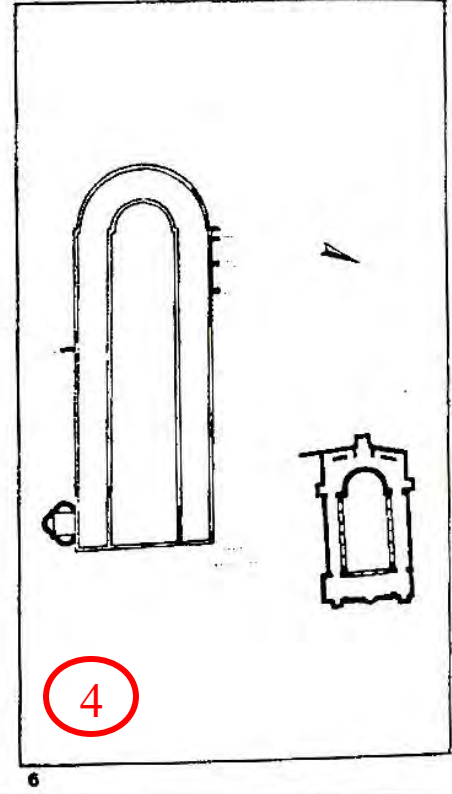
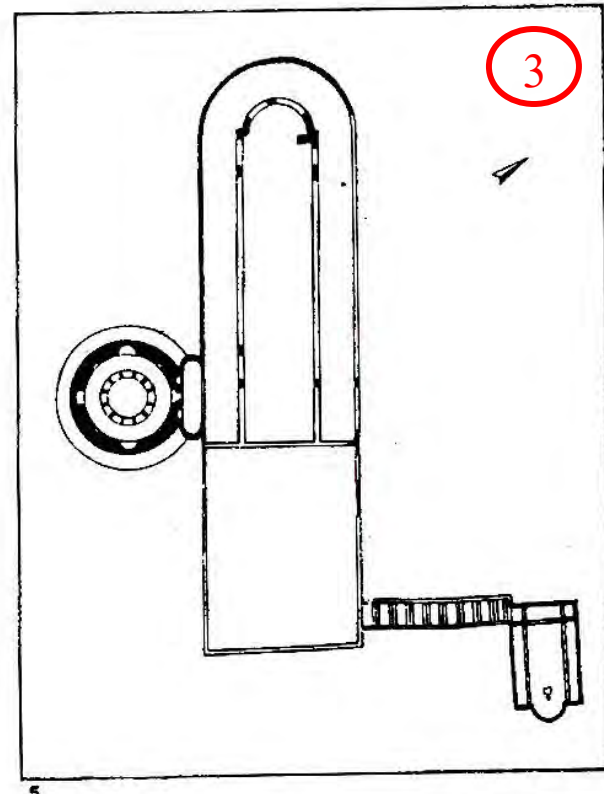
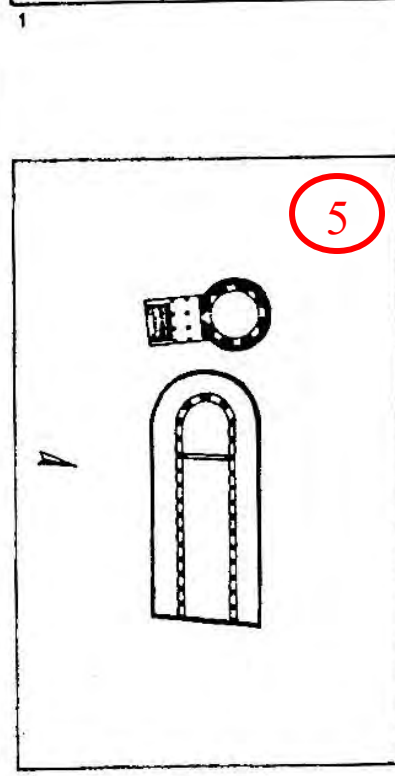

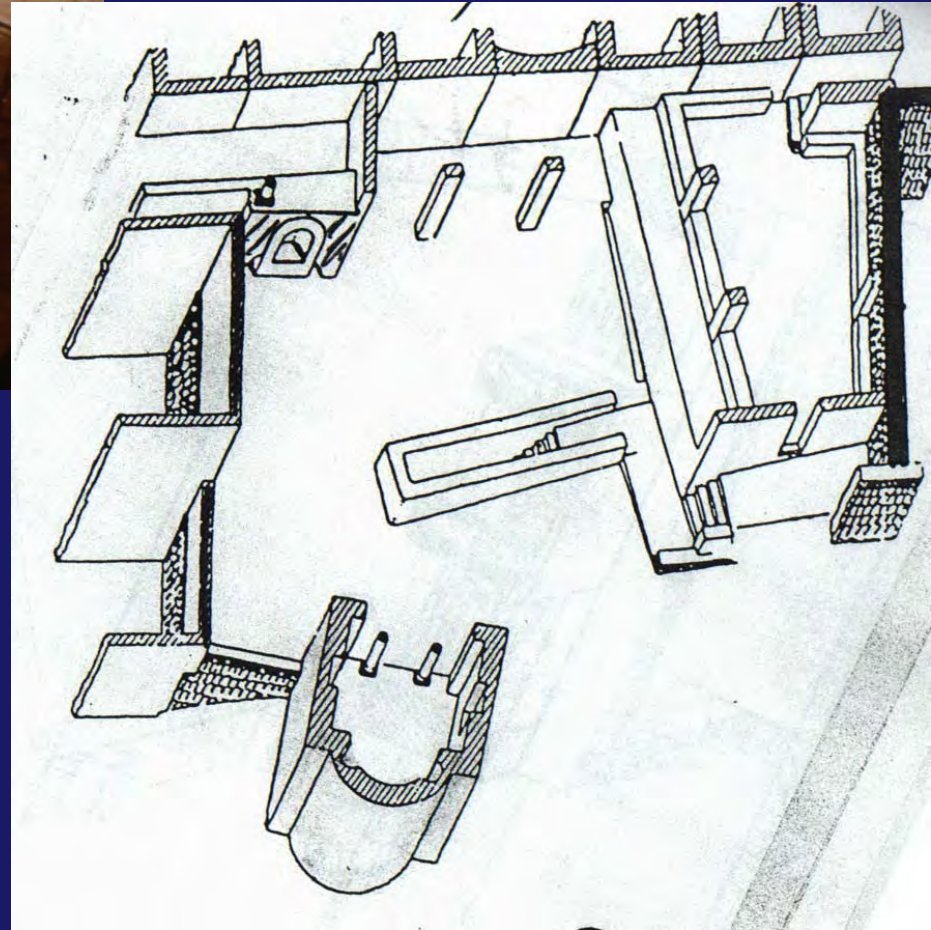

memoria Apostolorum

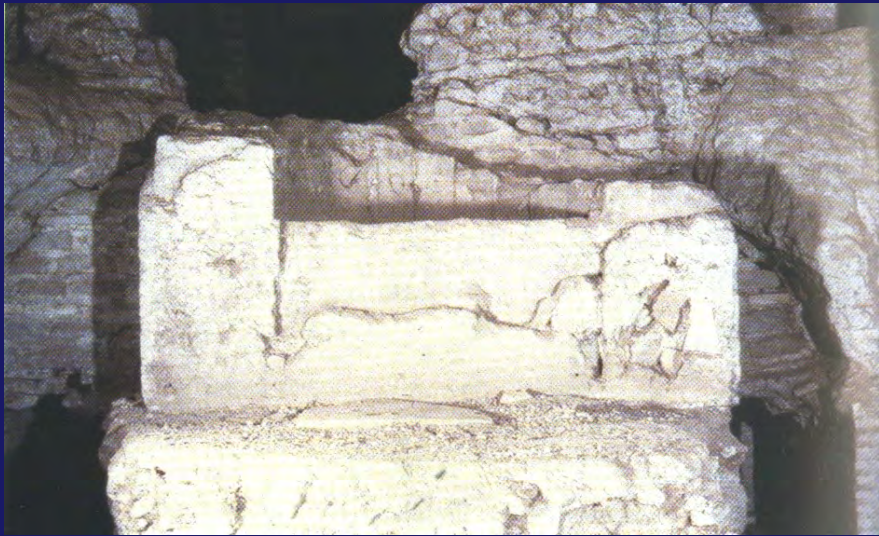

nicchia



graffiti

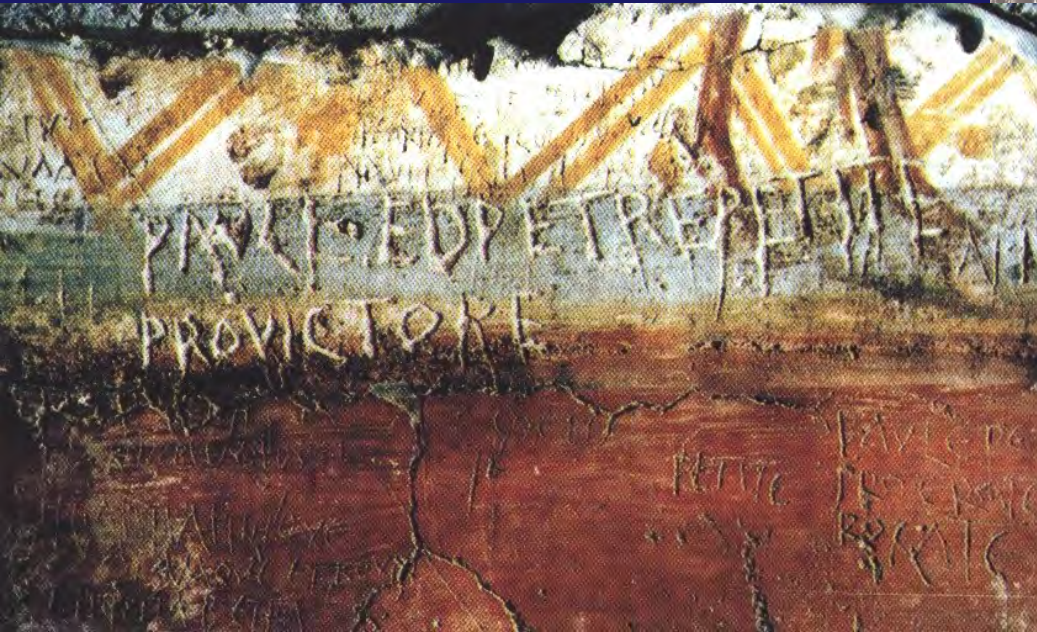

S. Sebastiano epigrafe damasiana

*Hic habitasse prius sanctos cognoscere debes
nomina quisq(ue) Petri pariter Pauliq(ue) requiris.
Discipulos Oriens misit, quod sponte fatemur;
sanguinis ob meritum Christumq(ue) per astra secuti
aetherios petiere sinus regnaque piorum:
Roma suos potius meruit defendere cives.
Haec Damasus vestras referat, nova sidera, laudes.*

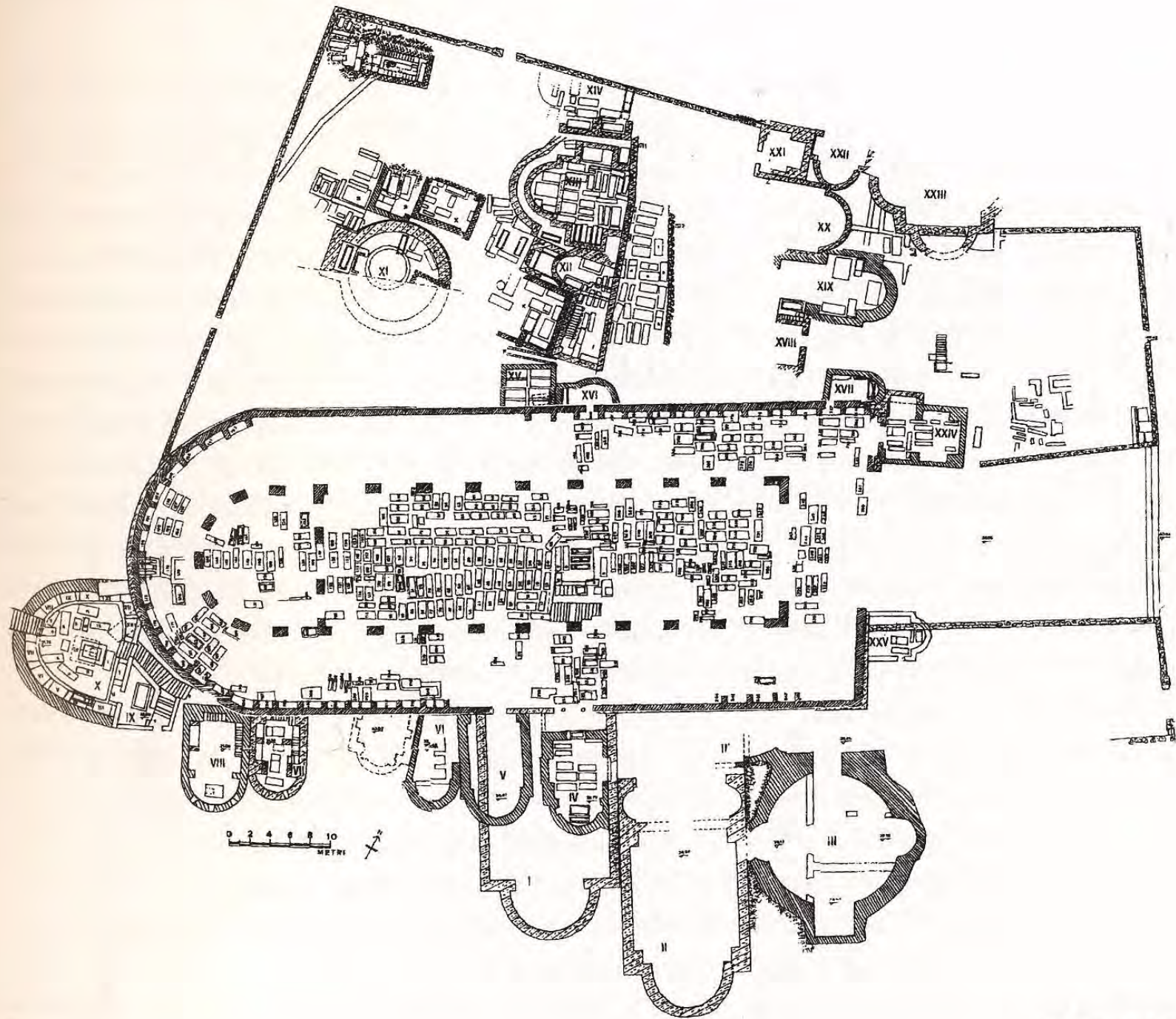



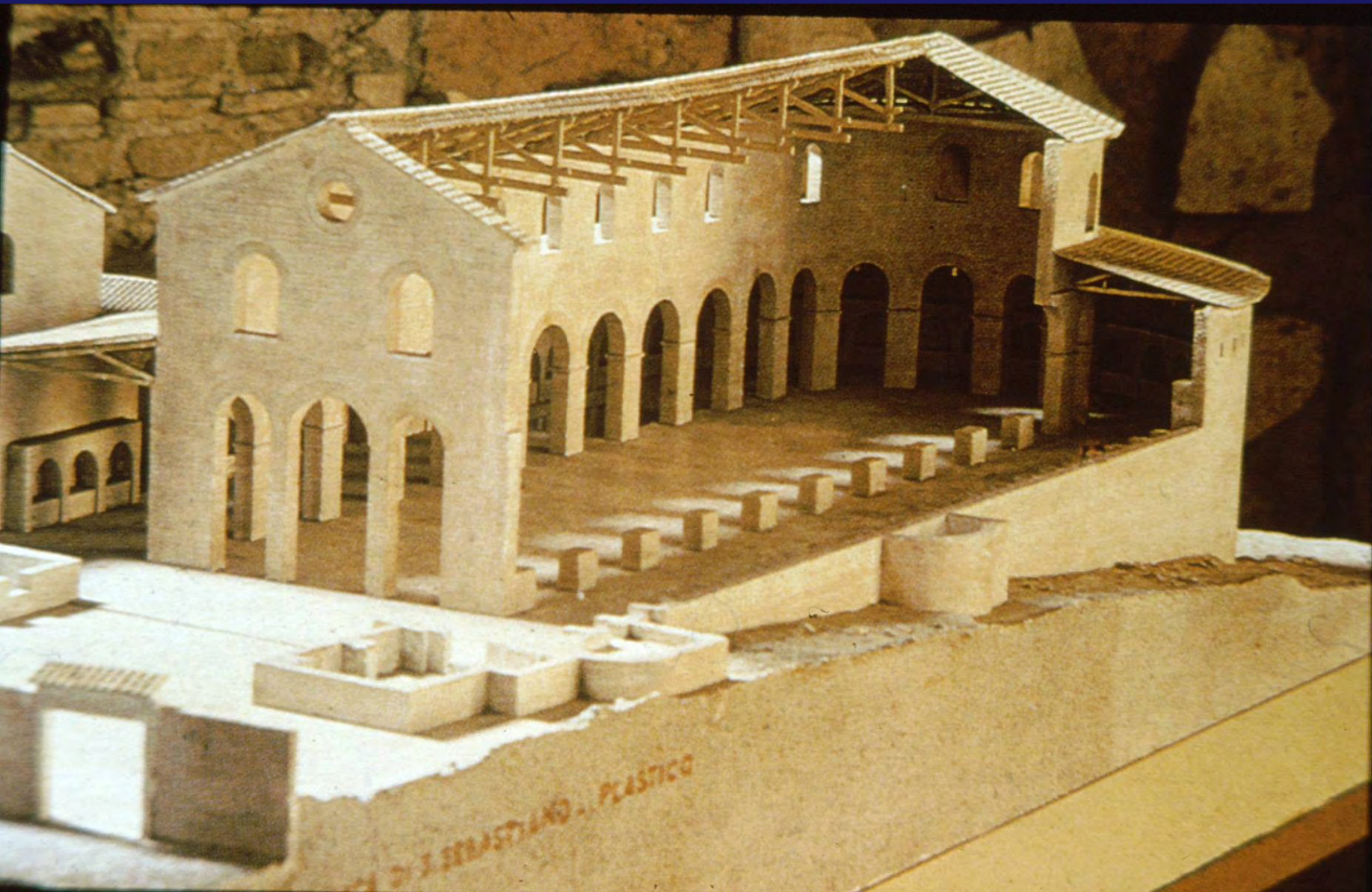

Circo di Massenzio 306-309



LP I, 182-183

Eodem tempore

fecit Augustus Constantinus basilicam martyribus

Marcellino presbitero et Petro exorcistae

in territorio inter duos lauros

et mysileum

ubi mater ipsius sepolta est Helena Augusta, via Lavicana, miliario III.

In quo loco

et pro amore matris suae

et veneratione sanctorum

posuit dona voti sui







LP I, 180-181

*Eodem tempore fecit basilicam
sanctae martyris Agnae
ex rogatu filiae suae
et baptisterium
in eodem loco*

*ubi et baptizata est soror eius Constantia
cum filia Augusti a Silvestro episcopo,
ubi et constituit donum hoc*

Idem depositio martyrum

VIII. KAL. IAN.

Natus Christus in Betleem Iudeae.

MENSE IANUARIO.

XIII. KAL. FEB.

Fabiani, in Calisti, et Sebastiani, in Catacumbas.

XII. KAL. FEB.

Agnetis, in Nomentana.

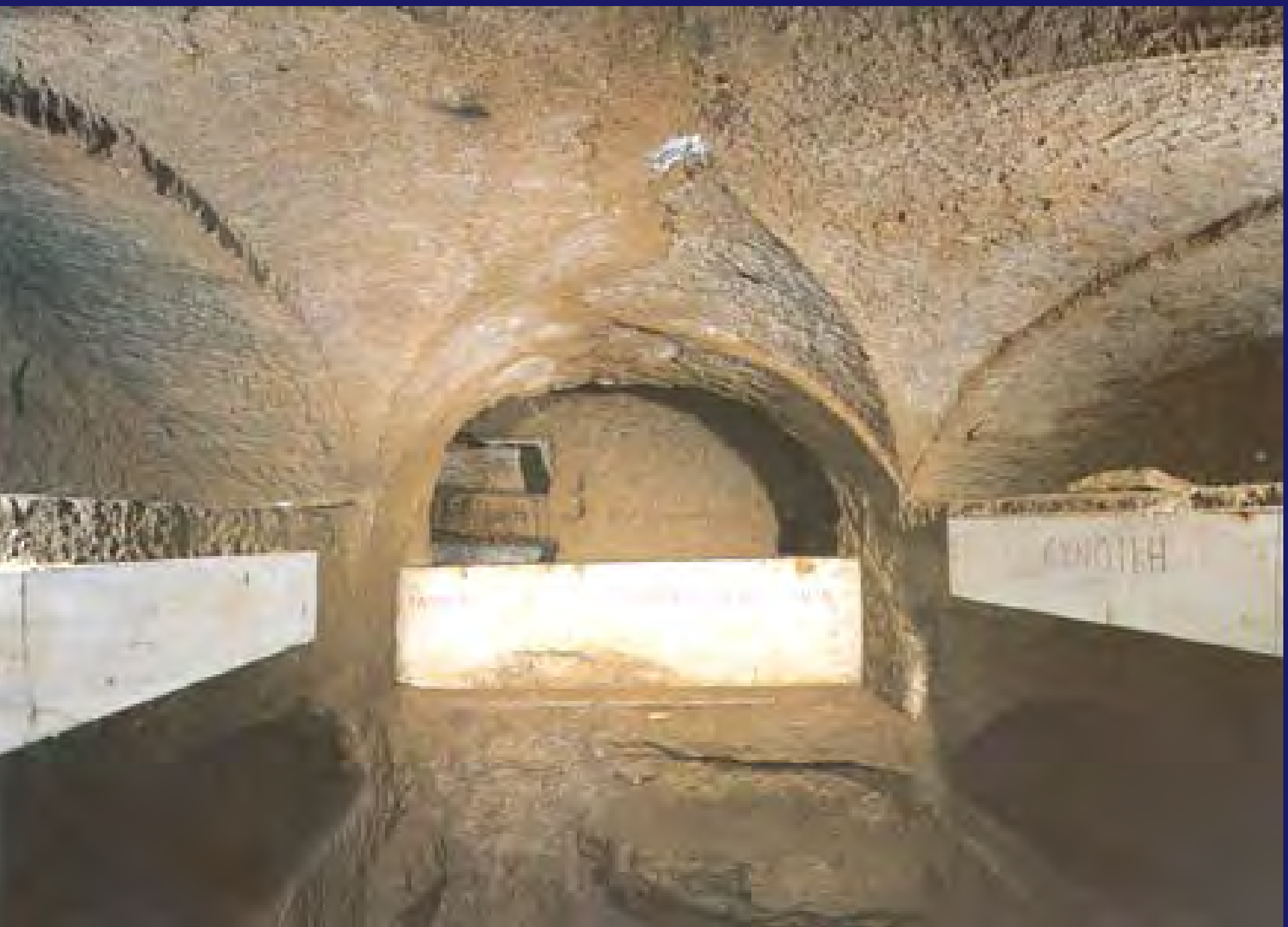

HISTORY

Informational panel text, partially obscured by the archway.

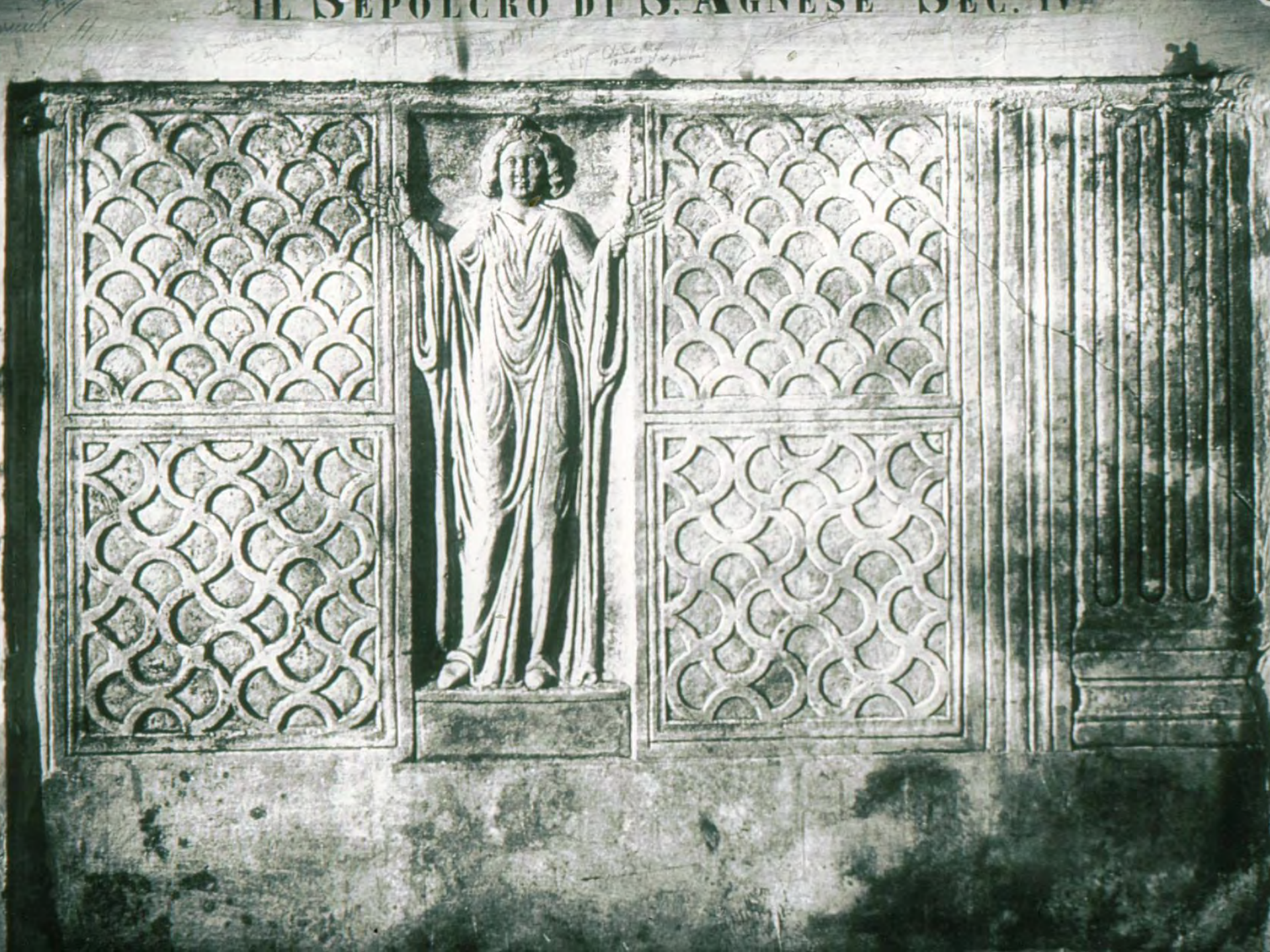

- *Regio I*
- *Regio III*
- *Regio IV*
- *Ipogei pagani*
- *Arenario*

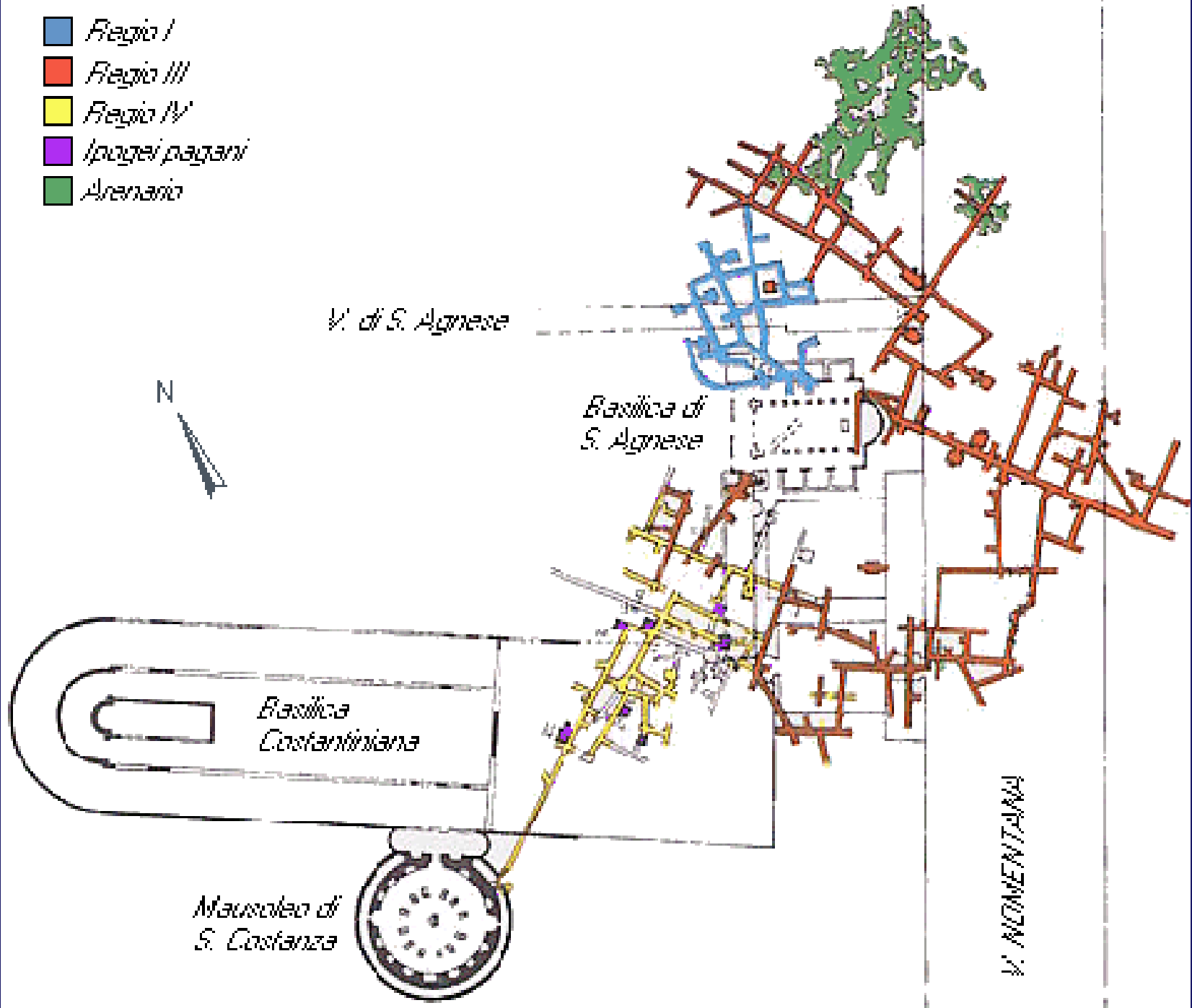



Mausoleo di Costantina

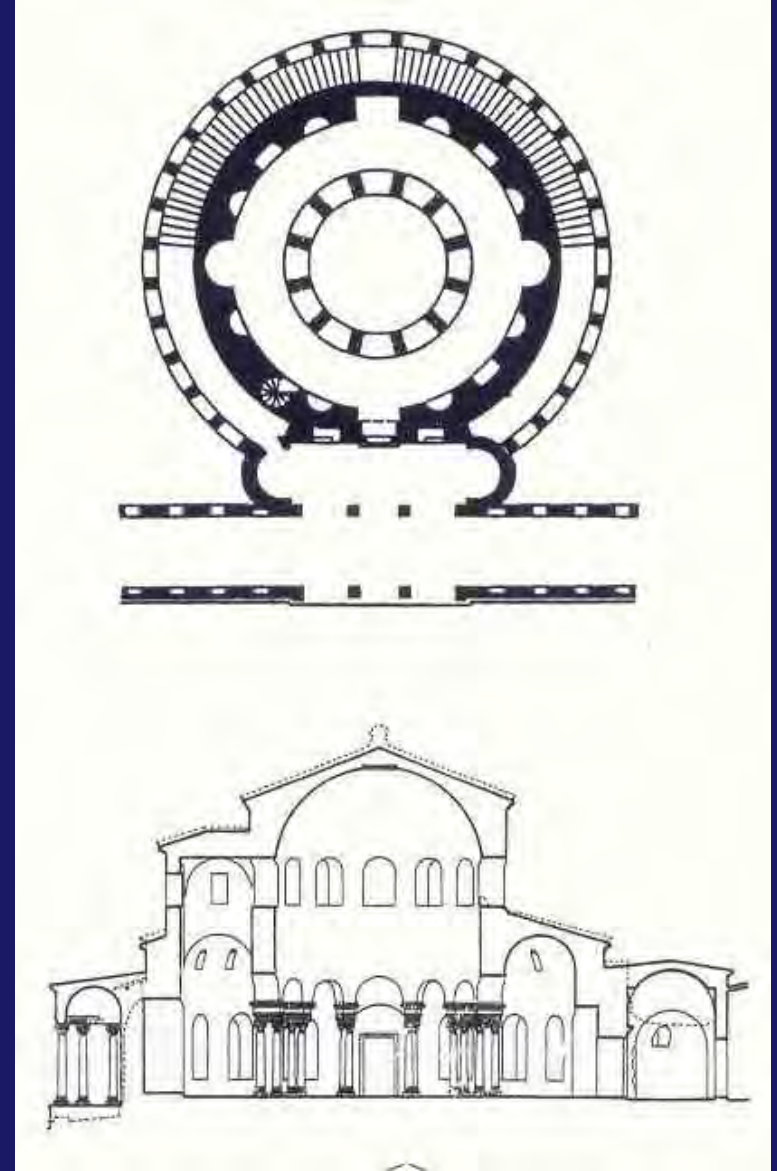





Basilica onoriana di S. Agnese



LP I, 181-182

*Eodem tempore
fecit basilicam beato Laurentio martyri
via Tiburtina in agrum veranum
supra arenario cryptae
et usque ad corpus sancti Laurenti martyris
fecit gradus ascensionis et descensionis.
In quo loco construxit absidam
et exornavit marmoribus purphyreticis
et desuper loci conclusit de argento
et cancellos de argento purissimo ornavit. [---]
et ante ipsum locum in crypta posuit...*





VIA TIBURTINA

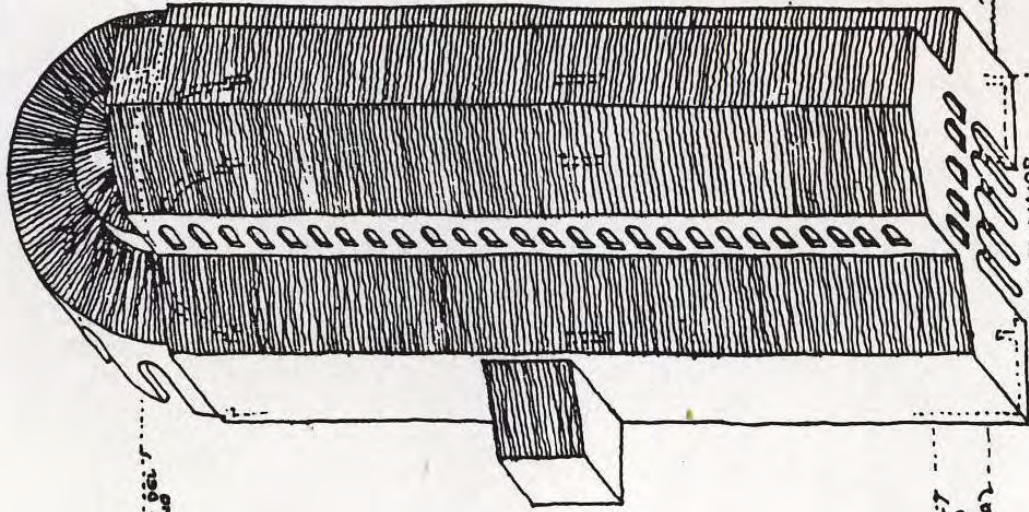

MURO DEL T. VERANO

QUADRI-7
PORTICO
DEL
VERANO

BASILICA MAIOR
(- 2.17)

S. LORENZO FUORI
LE MURA

CONCINA
(10.00)

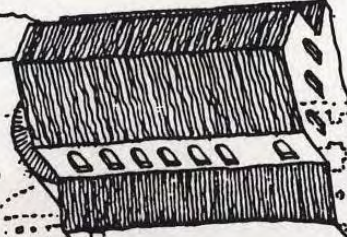

DELICIANA

CONVENTO

CHIOSTRO

TORRE DEI
CAPUCCINI



CONVENTO



W. Tr. 9. 9. 57.

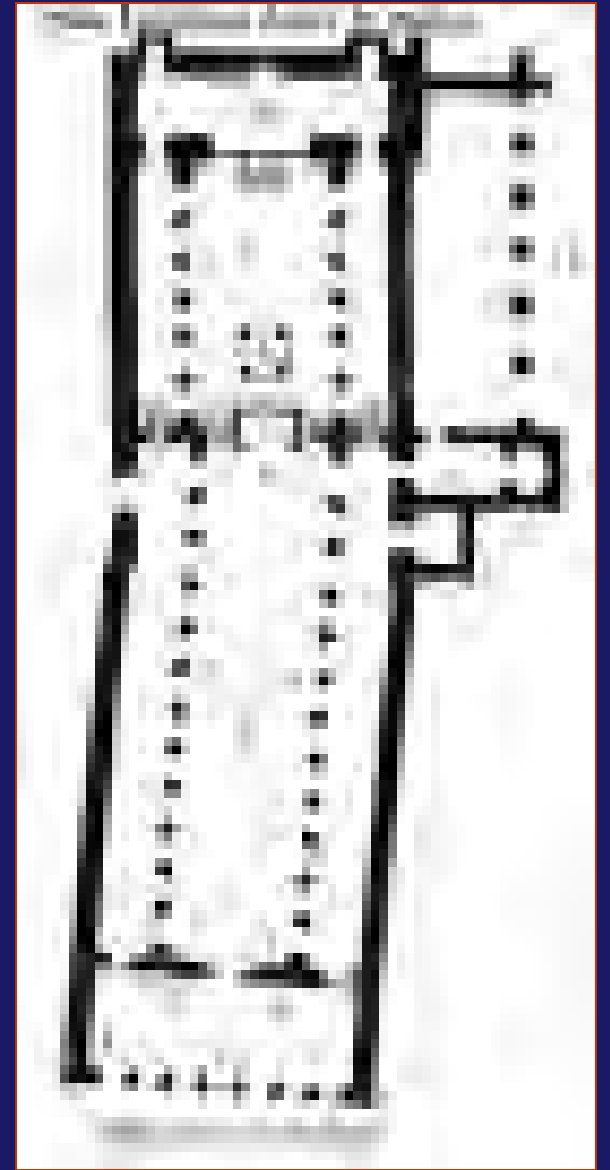



Villa dei Gordiani

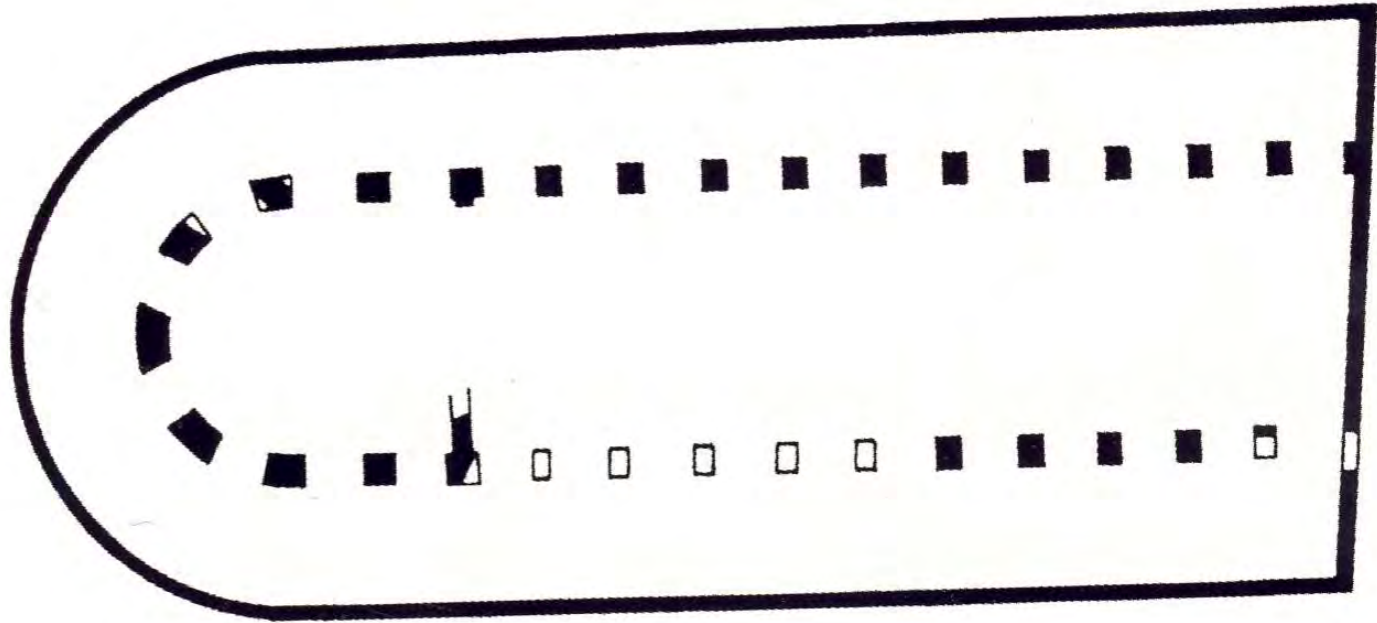
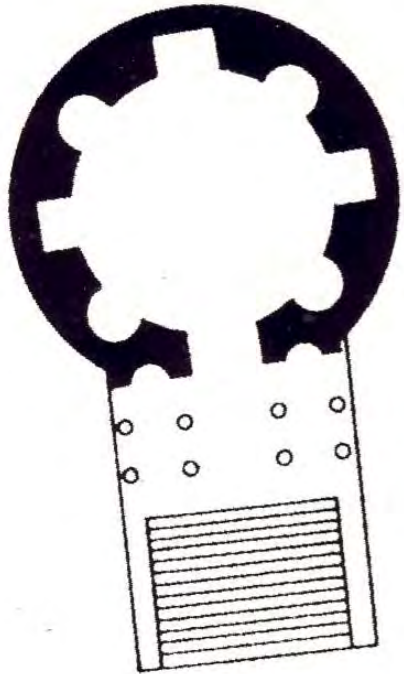



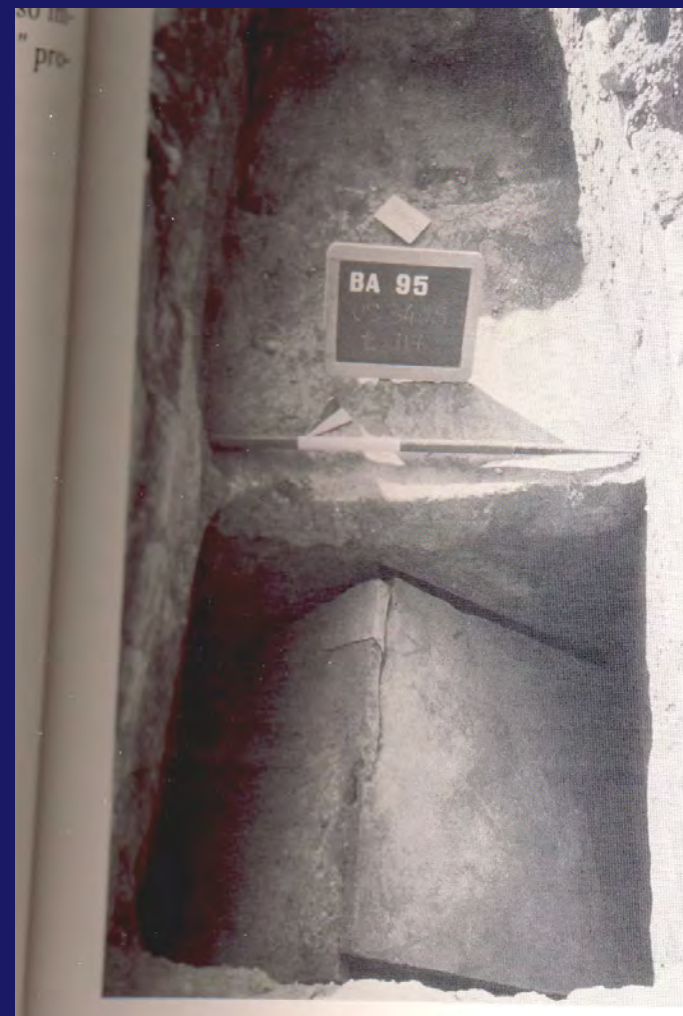

LP I, 202

*Hic fecit duas basilicas,
unam via Ardeatina ubi requiescit
et aliam in urbe Roma iuxta Pallacinis.*

*Ex huius suggestione
obtulit Constantinus Augustus basilicae
quem cymiterium constituit via Ardeatina
(elenca doni)*

[---]

*Qui etiam sepultus est in cymiterio Balbinae,
via Ardiatina,
quem ipse insistens fecit...*

Depositio episcoporum

.VI KAL. IANUARIAS	Dionisi, in Calisti.
.III KAL. IANUAR.	Felicis, in Calisti.
PRID. KAL. IANUAR.	Silvestri, in Priscillae.
.IIII. IDUS IANUARIAS	Miltiadis, in Calisti.
.XVIII. KAL. FEBR.	Marcellini, in Priscillae.
.III. NON. MART.	Luci, in Calisti.
.X. KAL. MAI.	Gai, in Calisti.
.IIII. NON. AUGUSTAS	Stephani, in Calisti.
.VI. KAL. OCTOBR.	Eusebii, in Calisti.
.VI. IDUS DECEMBR.	Eutichiani, in Calisti.
NON. OCTOBR.	Marci, in Balbinae.
PRID. IDUS APRIL.	Iulii in via Aurelia, miliario. III. in Calisti ¹ .

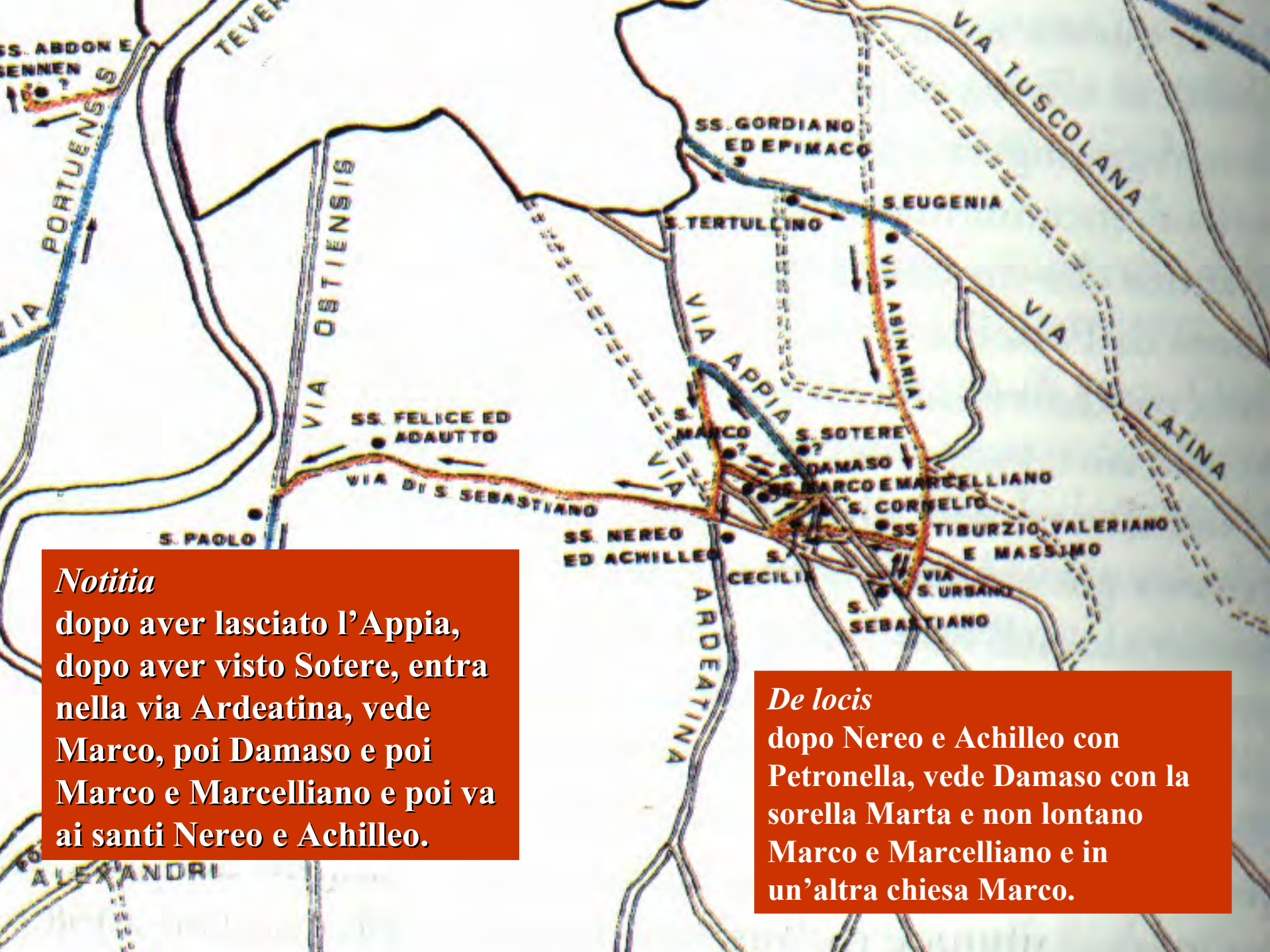

Notitia

dopo aver lasciato l'Appia, dopo aver visto Sotere, entra nella via Ardeatina, vede Marco, poi Damaso e poi Marco e Marcelliano e poi va ai santi Nereo e Achilleo.

De locis

dopo Nereo e Achilleo con Petronella, vede Damaso con la sorella Marta e non lontano Marco e Marcelliano e in un'altra chiesa Marco.



ISTITUTO S. MARCISIO

**martiri
greci**

**Marco,
Marcelliano e
Damaso**

Papa Marco

VIA ARDEATINA

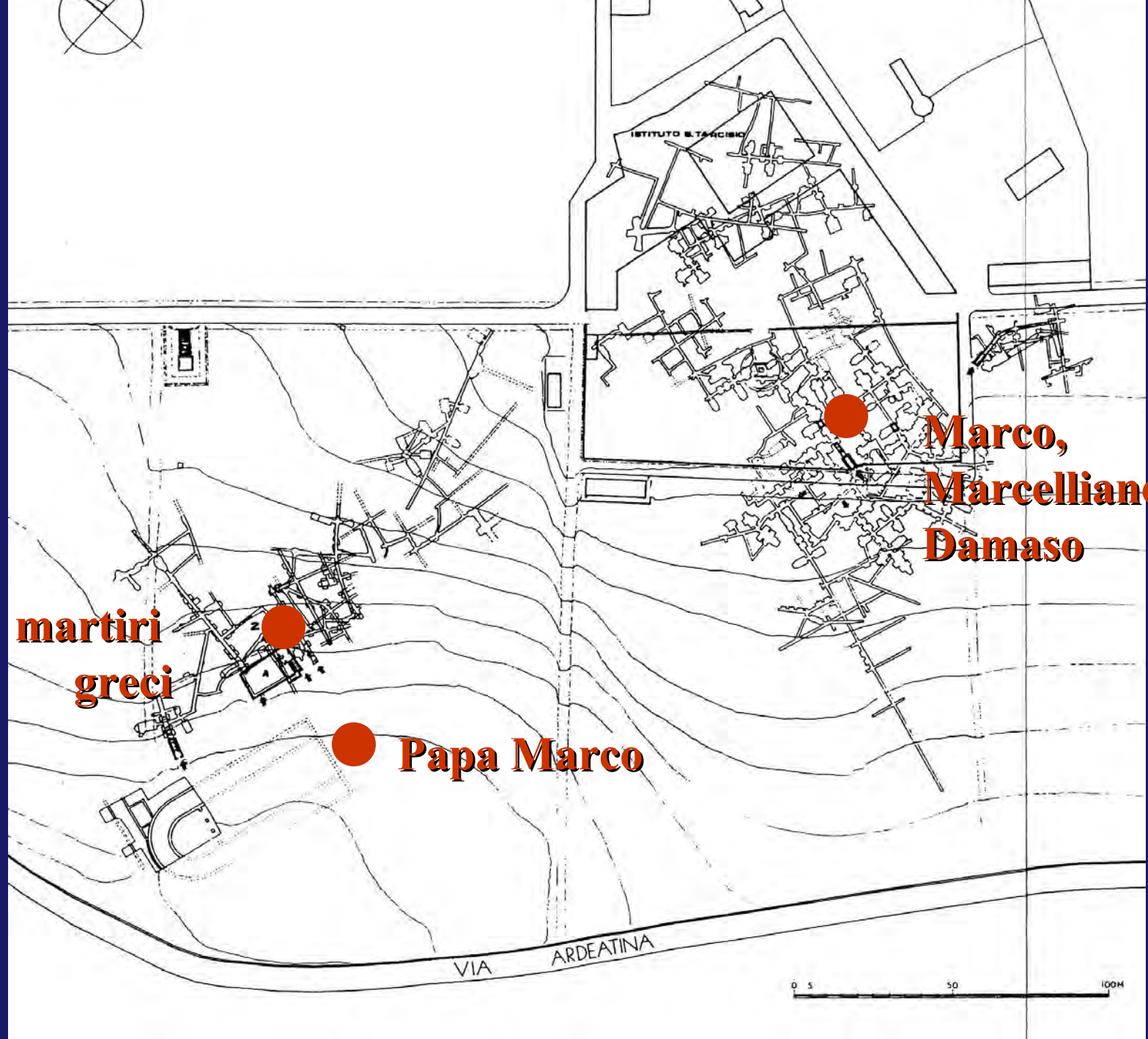
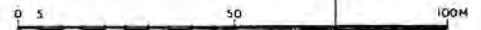

Catacomba anonima dell'Ardeatina

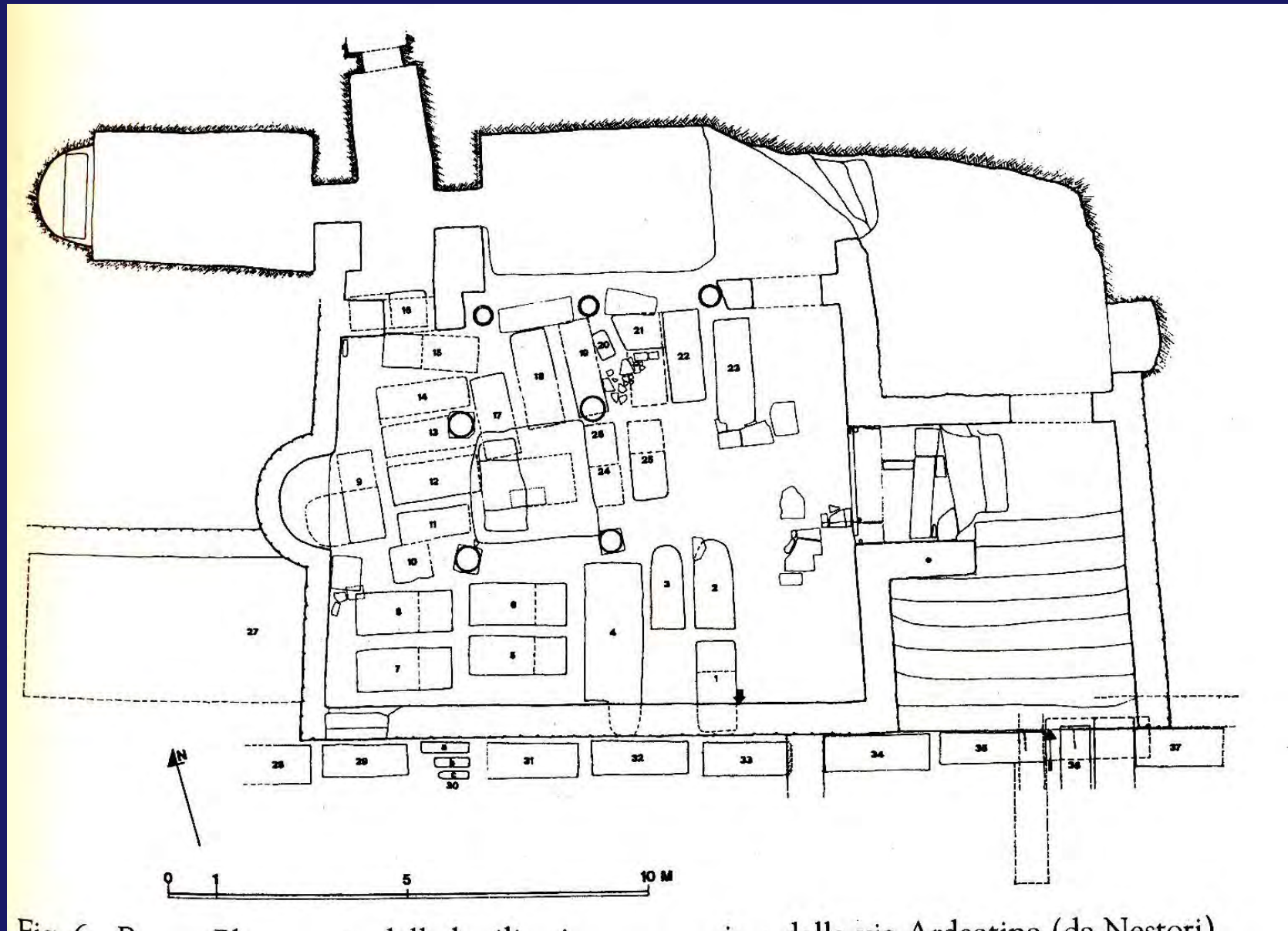
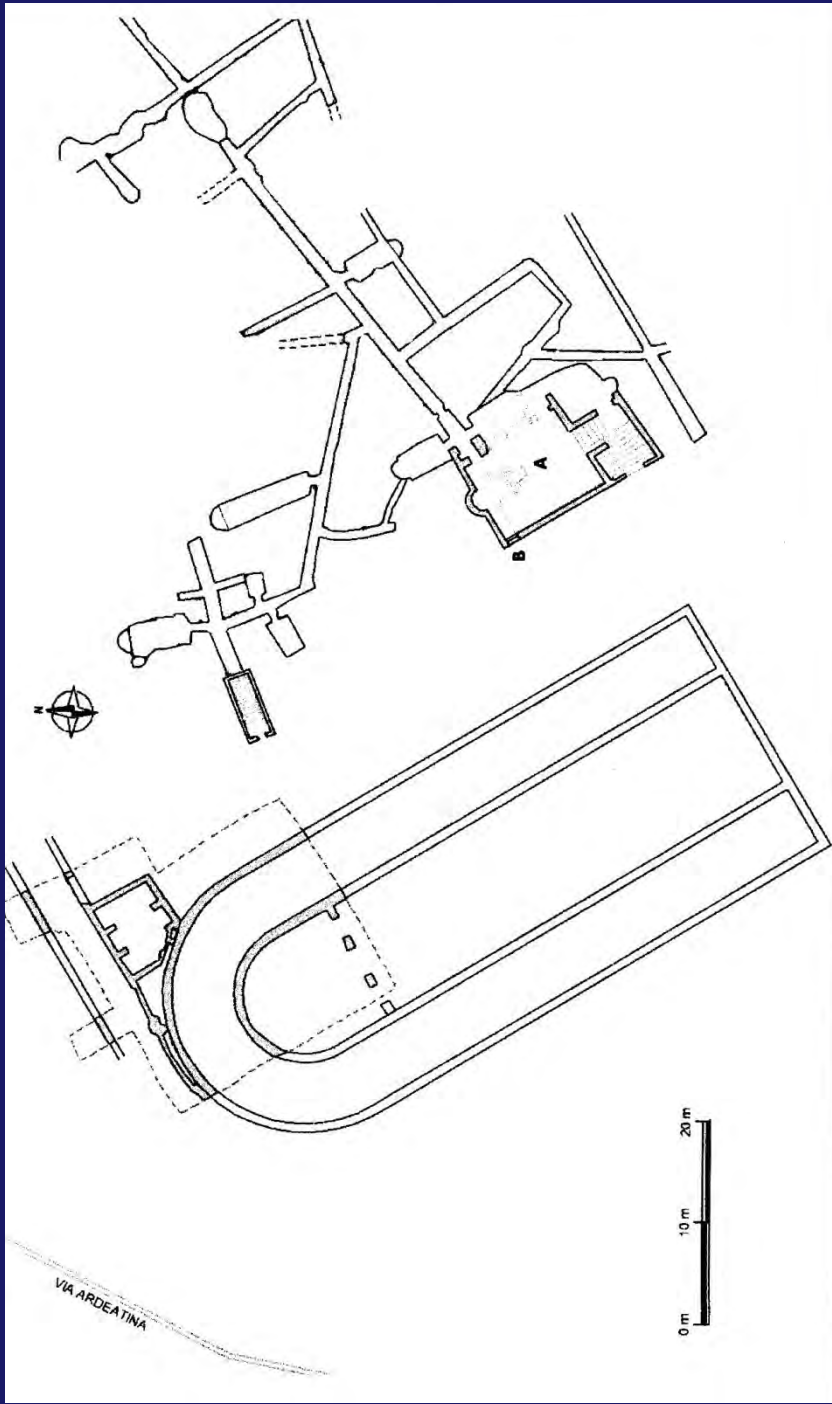

Fig. 6. P. D. Plan of the anonymous catacombs of the Ardeatina (de Nestori)







Basilica di papa Marco

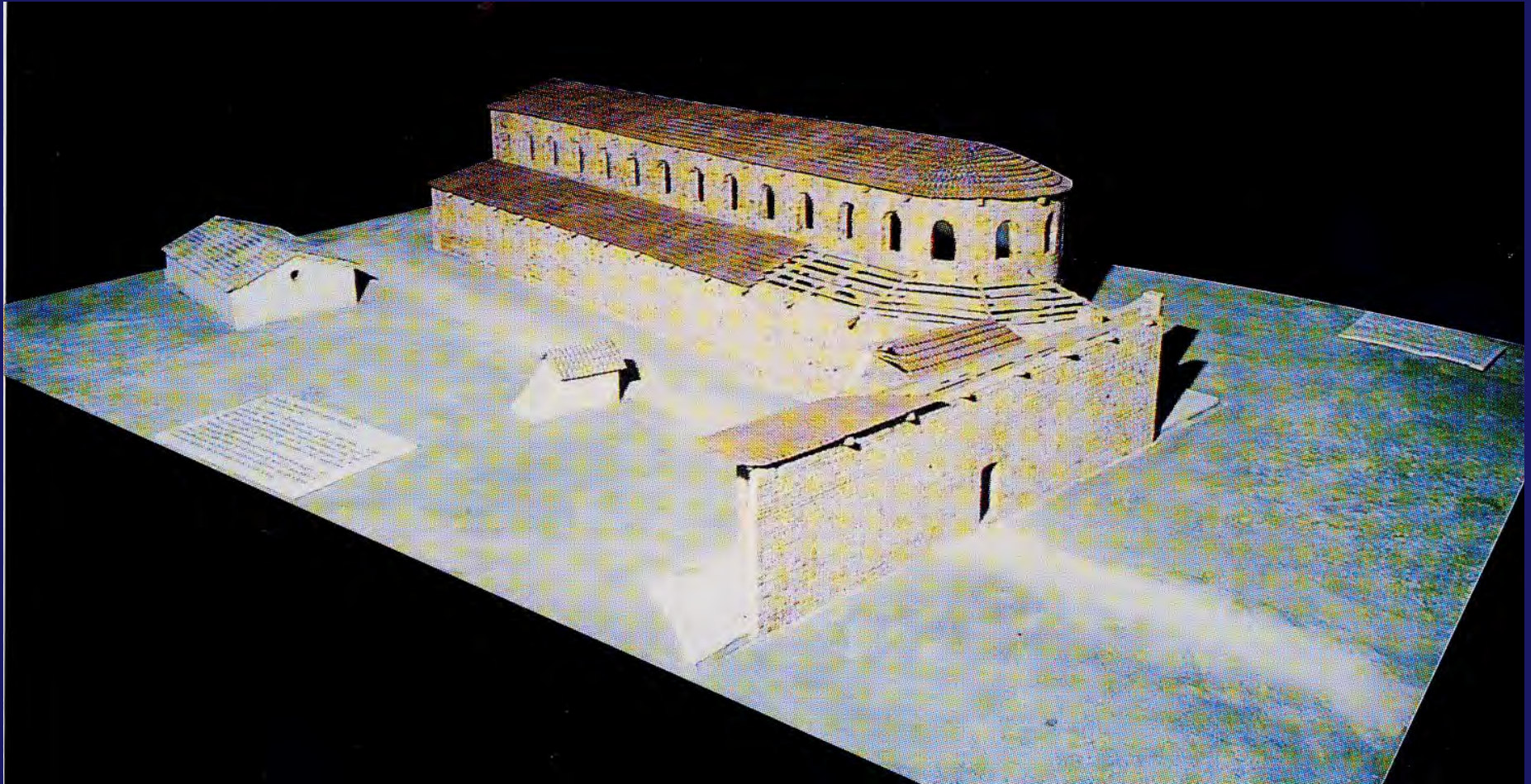



**Ritratto
di Damaso
a S. Paolo
f.l.m.**

«impresario»
dei martiri a
Roma

Liber Pontificalis I, 212

*Hic multa corpora sanctorum
requisivit et invenit,
quorum etiam versibus declaravit*

Interventi di Damaso

- Epigrafi
- Abbellimento di cubicoli e tombe
- Facilitare il percorso dei pellegrini

D
A
M
A
S
C
E
N
S
I
P
A
P
P
A
E
C
V
L
I
O
R
A
I
Q
V
E
A
M
A
T
O
R

DAMASVS EPISCOPVS FECIT
CLIVSVE IVIT LABSOSPECCATA DOLERE
SEBIVSMISEROS DOCVITSVACRIMINA FLERE
SCIENTIVRINPARTESCIVITGLISCENTEFVRORE
SEDEHOC A EDESPICIVITDISCORDIALITES
EXTEMPILOPARITERIVSHERITAT TYRANNI
INTEGRACVMRECTORSERVAREFOETTERAPACIS
PERTVLITEXILIVMDOMINOSVBVNDICELAEIVS
LITORETRINACRIOMVNDVMVIIAMIQRELIQVIT
EVSEBIOEPISCOPOETMARTYRI

F
V
R
I
V
S
D
I
O
N
Y
S
I
V
S
F
L
O
C
A
I
V
S
S
C
R
I
B
I
T

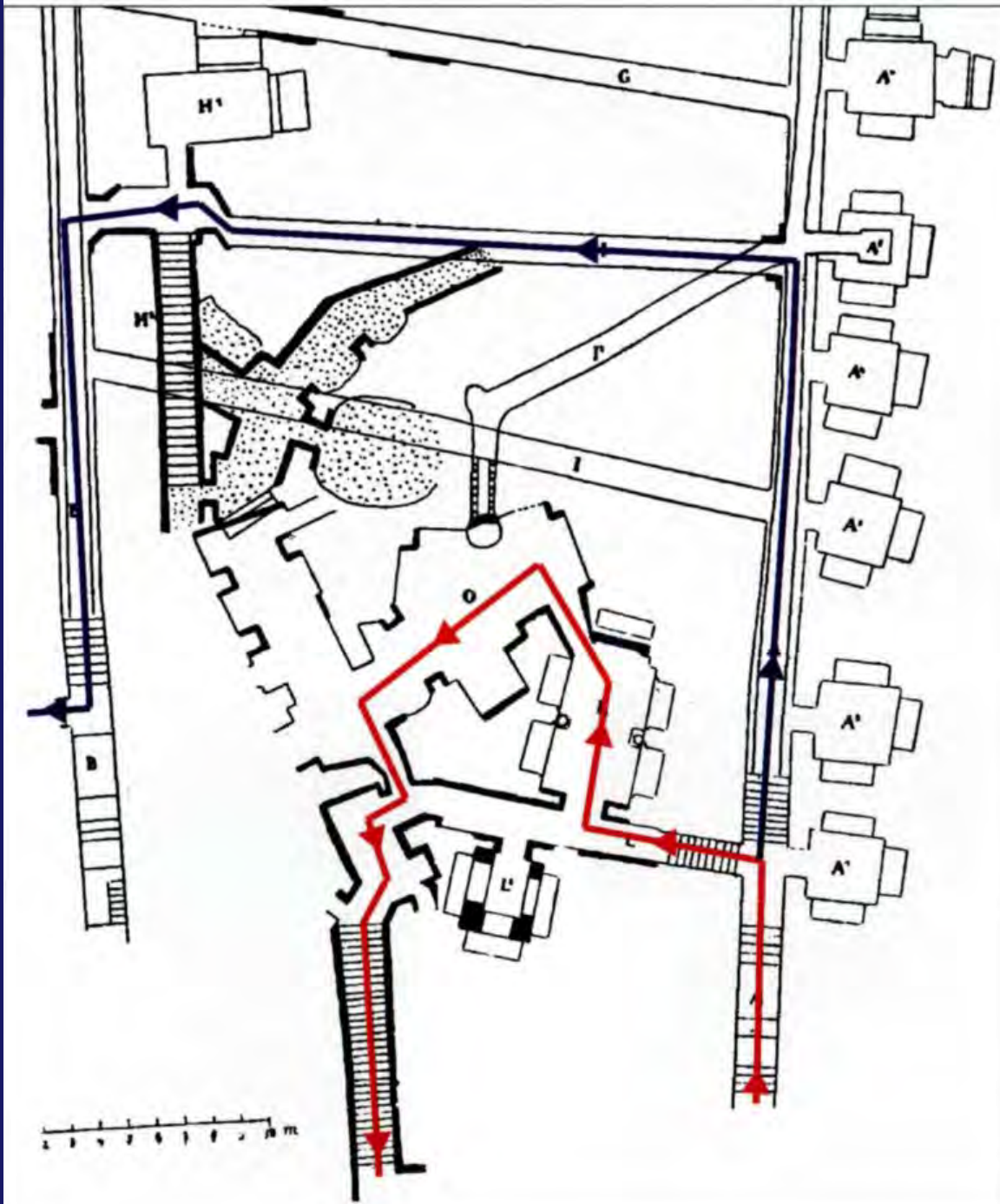

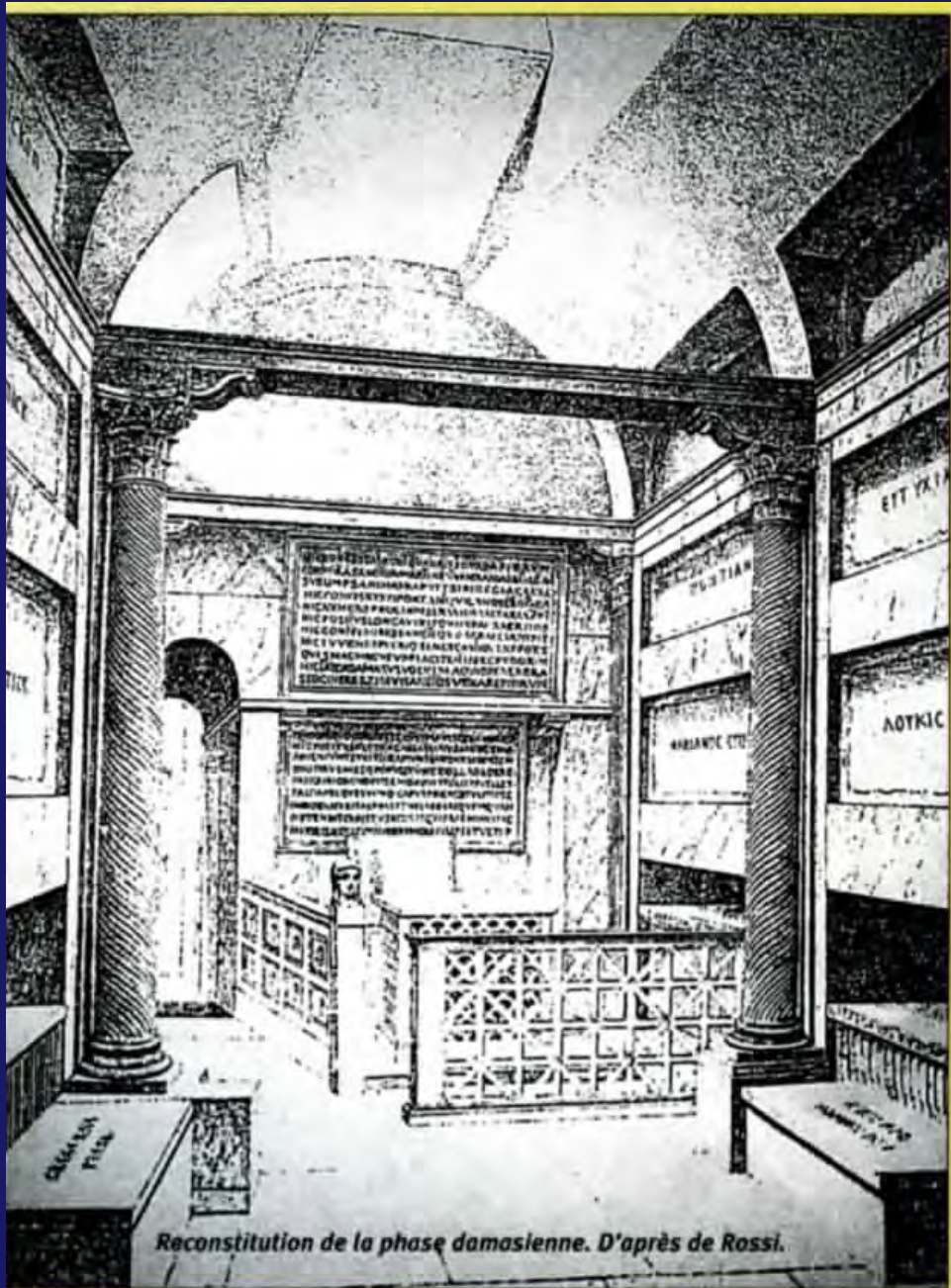

Cripta dei papi

Reconstitution de la phase damasienne. D'après de Rossi.

Restituzione (Barbara Mazzei)

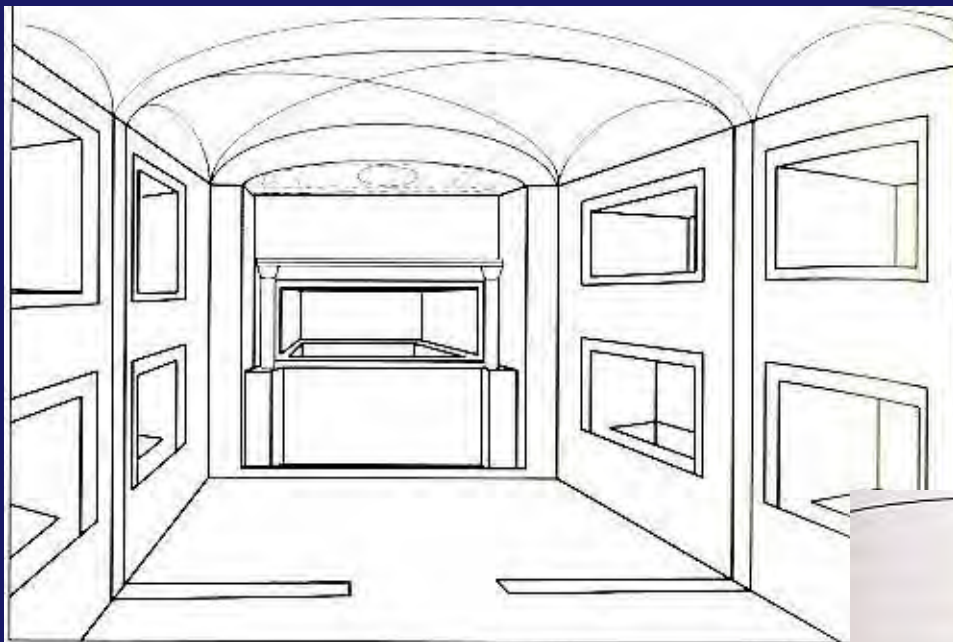



Catacomba di Pretestato

*Tomba
del martire
Gennaro*

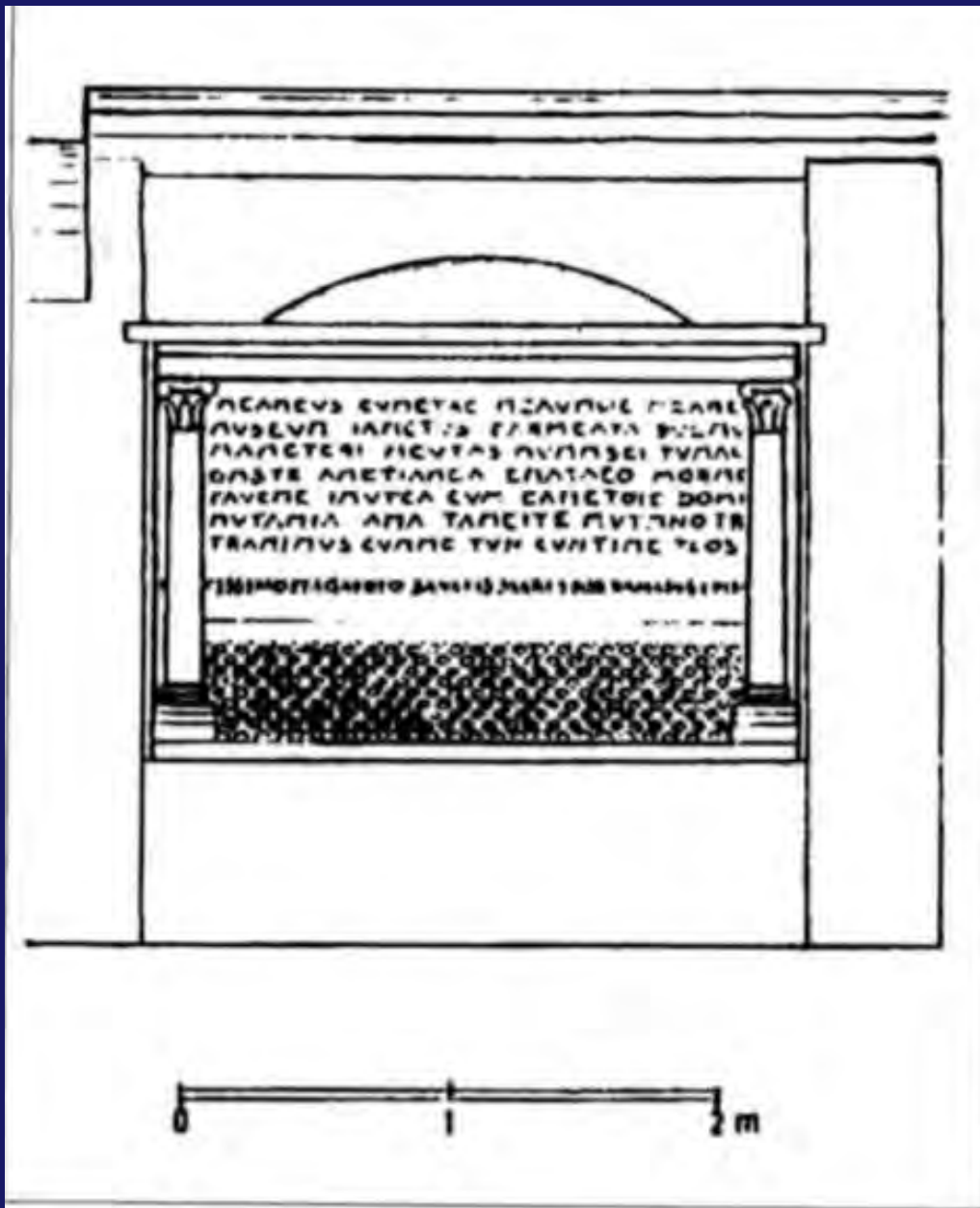

Catacomba di Pretestato

*Cripta dei
diaconi
Felicissimo e
Agapito*



SS. Marcellino e Pietro

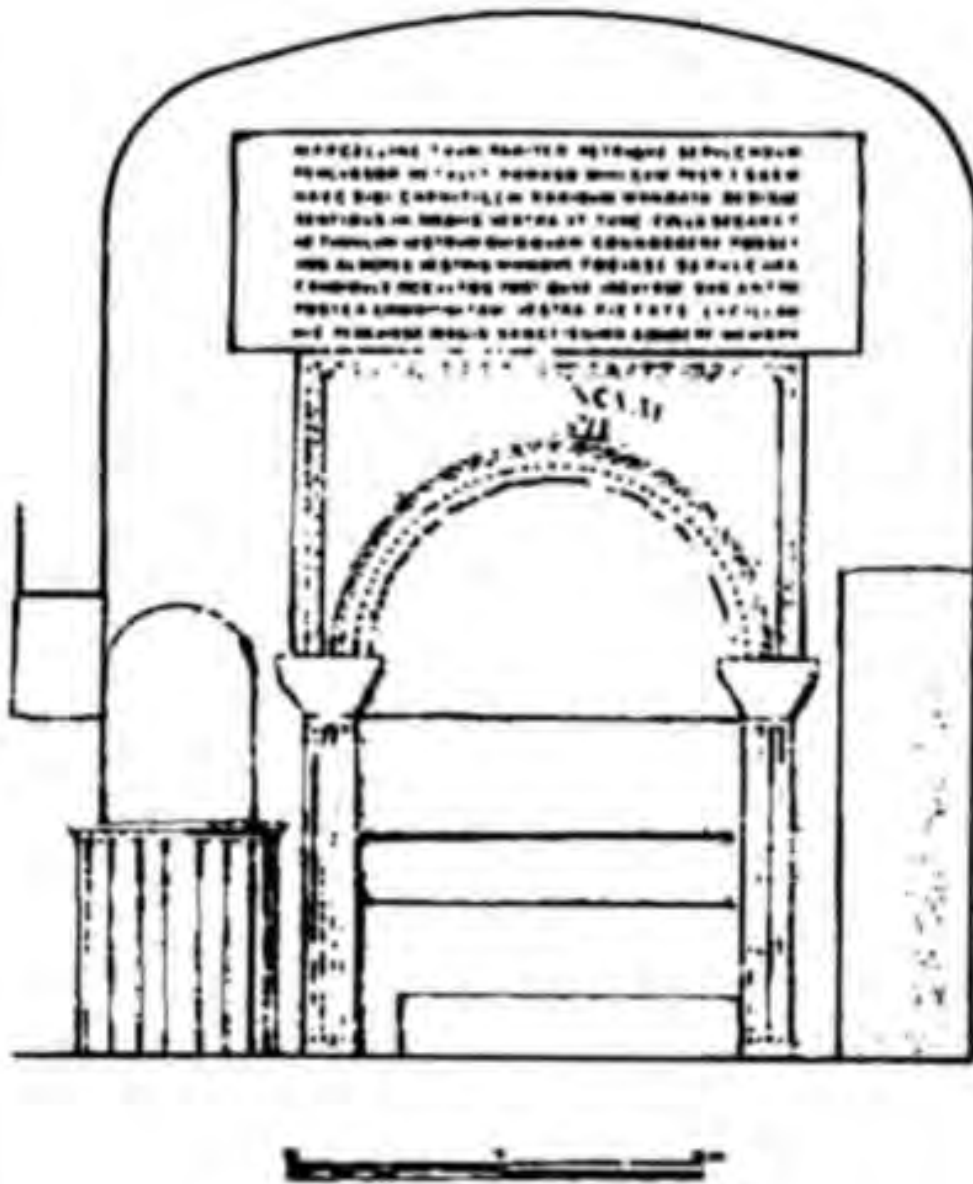

Catacomba
ad duas lauros

Cubicolo dei
SS Marcellino e
Pietro

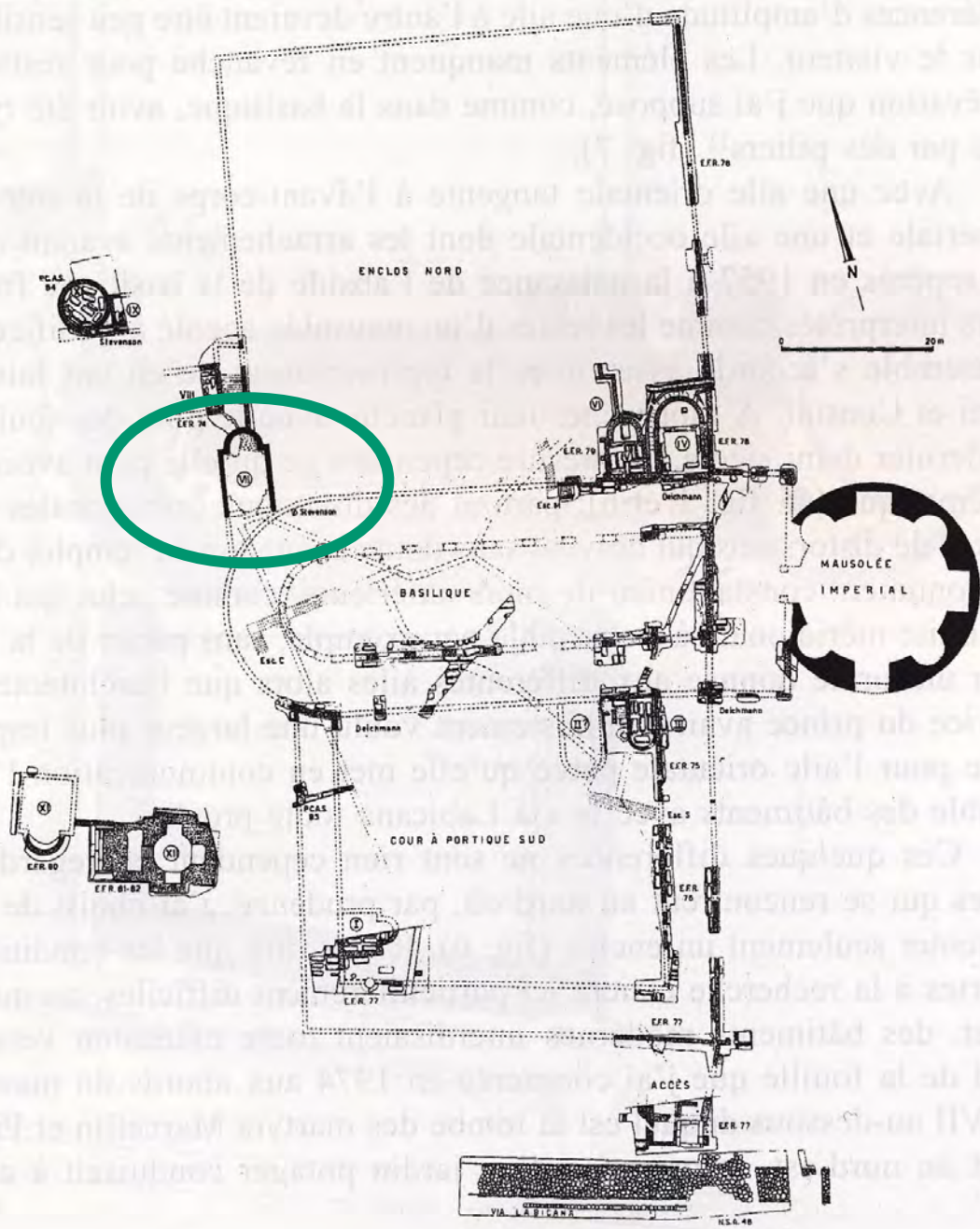

Commodilla



FIGURA 4
Via Salaria *nova*. Catacomba dei Giordani





PLAN 1

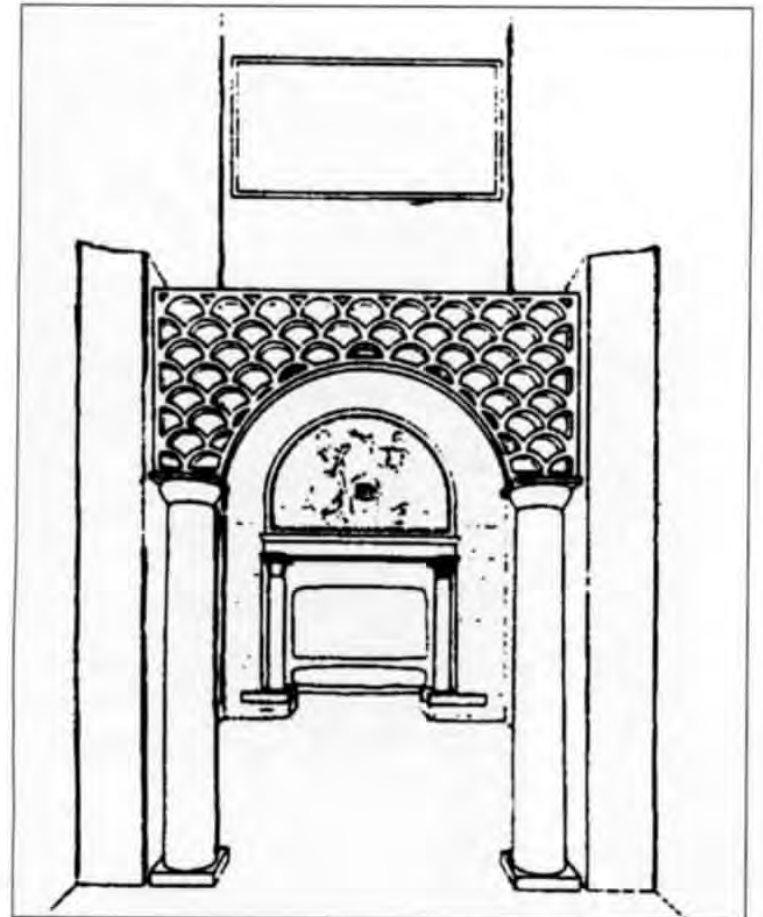
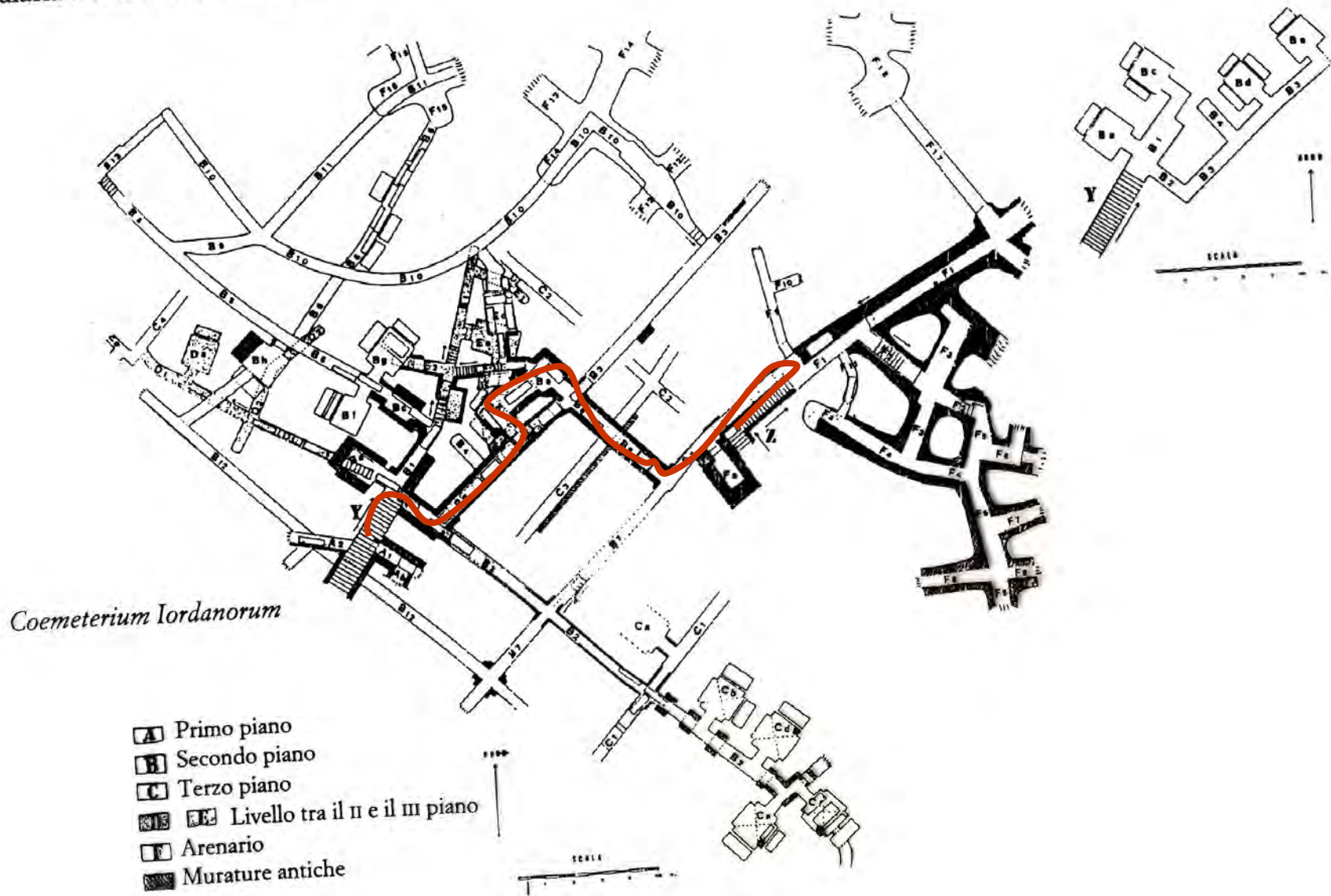
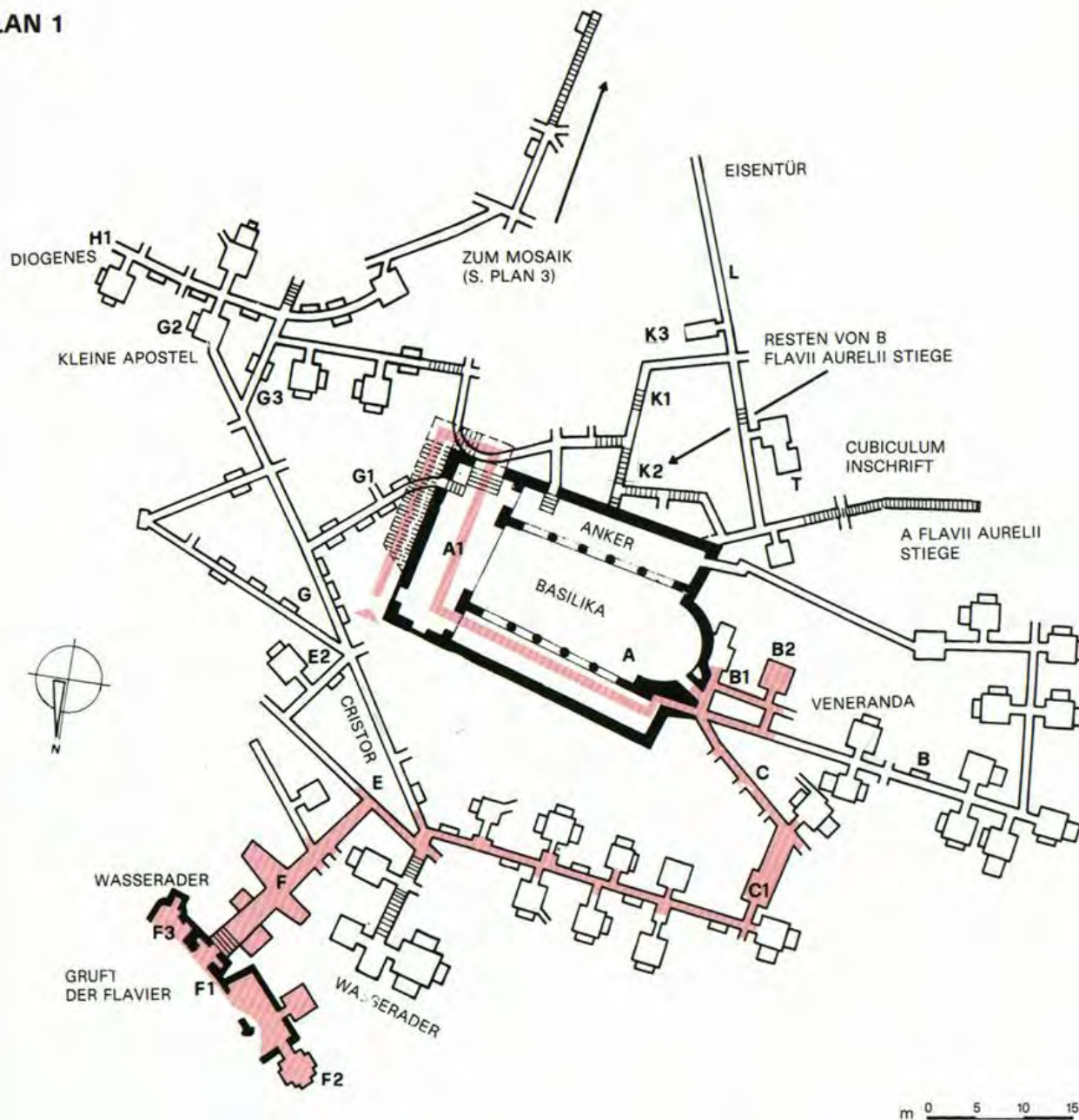

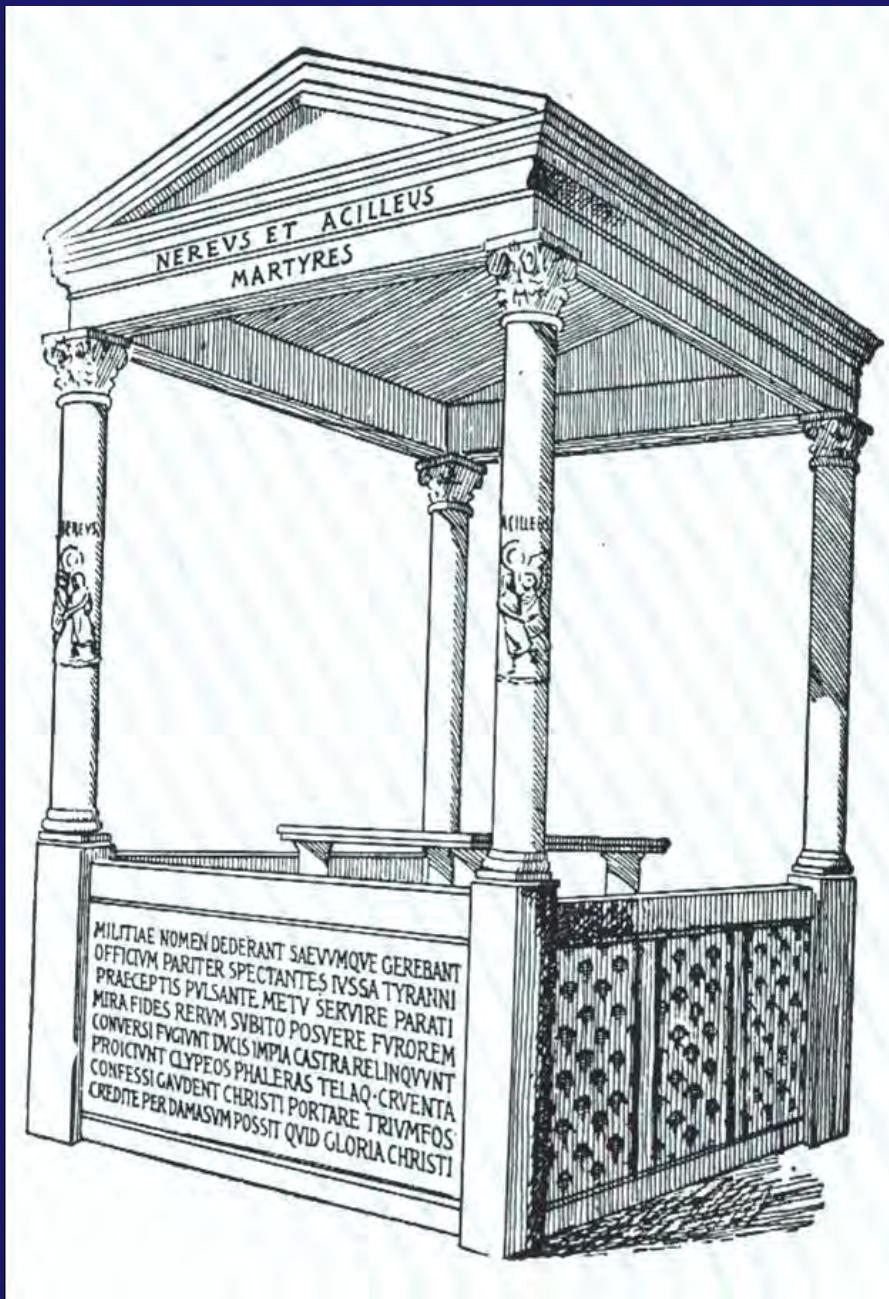

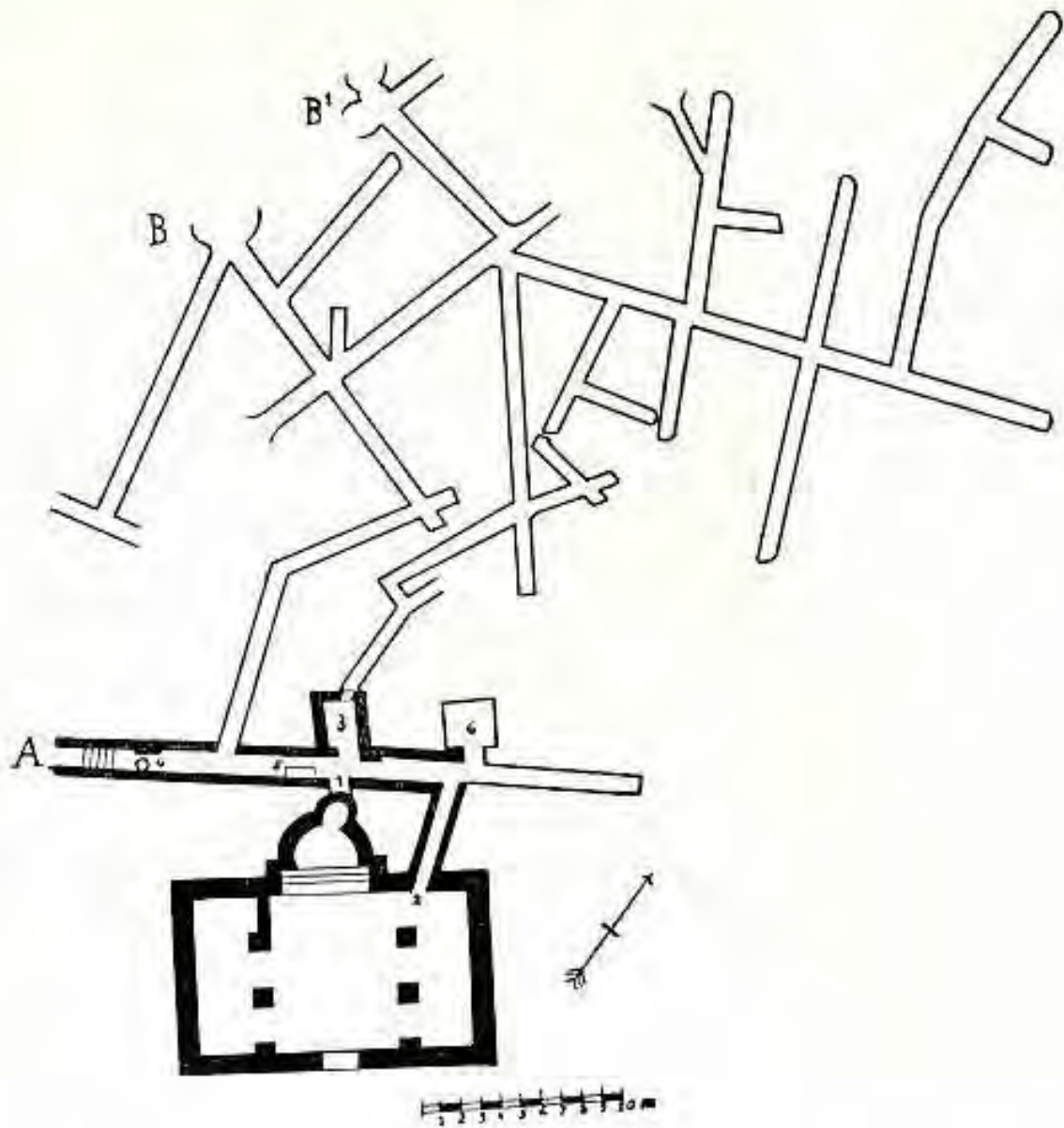









STINO VIATRICE

bibliografia essenziale

- **L. Pani Ermini, *Santuario e città fra tarda antichità e altomedioevo*, in “*Santi e demoni nell’Alto medioevo occidentale, secoli V-XI*”. *Atti della XXXVI Settimana di Studio del Centro Italiano di Studi sull’Alto medioevo (Spoleto, 7-13 aprile 1988)*, Spoleto 1989, pp. 837-877.**
- ***Akten des XII. Internationalen Kongresses für Christliche Archäologie (Bonn, 22.-23. September 1991)*, Città del Vaticano-Münster 1995.**
- **R. Santangeli Valenzani, *Pellegrini, senatori e papi: gli xenodochia a Roma tra il V e il IX secolo*, in *Rivista dell’Istituto Nazionale di Archeologia e Storia dell’Arte*, XIX-XX, 1997, pp. 203-336.**
- **V. Fiocchi Nicolai, *Strutture funerarie ed edifici di culto paleocristiani di Roma dal IV al VI secolo*, Città del Vaticano 2001.**
- **A. M. Giuntella, *Gli spazi dell’assistenza e della meditazione*, in “*Roma nell’alto medioevo*”. *XLVIII Settimana del Centro Italiano di Studi sull’Alto Medioevo (Spoleto, 27 aprile - 3 maggio 2000)*, Spoleto 2001, pp. 690-691.**